

ORIGINAL INSTRUCTIONS

S/N: 1153 AND ABOVE
PLEASE CONTACT GAGE BILT FOR
ALL OTHER SERIAL NUMBERS.

GB2581/GB2581A

INSTALLATION TOOL

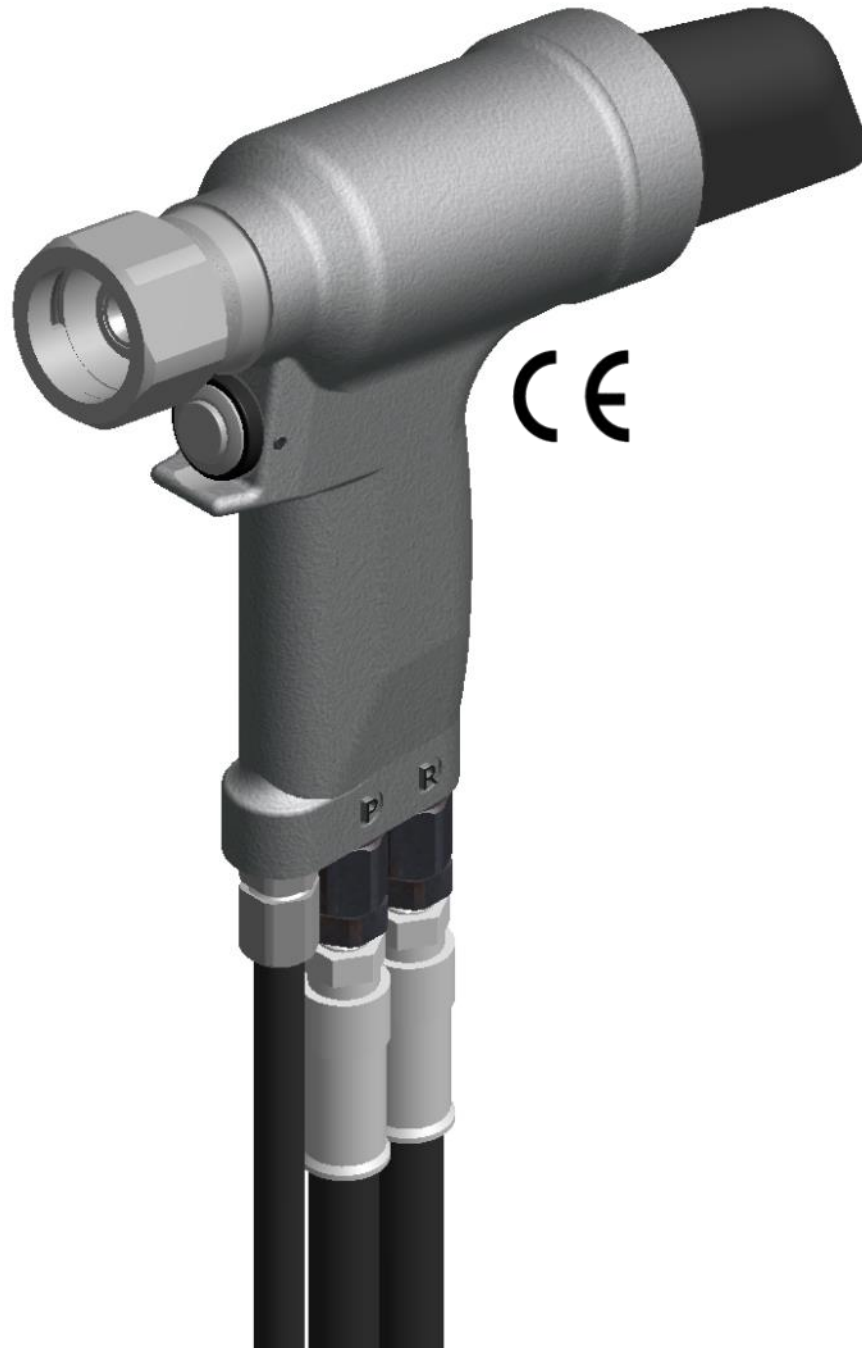

GAGE BILT TOOLS ARE AVAILABLE WORLDWIDE
E-MAIL US FOR DISTRIBUTOR NEAR YOU.

Registered to
ISO 9001:2015

GAGE BILT
 **MADE in USA**

44766 Centre Court, Clinton Twp., MI. 48038 USA
Ph: +1 (586) 226-1500 Fax: +1 (586) 226-1505
solutions1@gagebilt.com / www.gagebilt.com

TABLE OF CONTENTS



	<u>Page</u>
EU Conformity and Warranty	3
Description and Technical Specifications	4
Description of Functions	5
Safety Warnings	6
Principle of Operation	7
How to set-up the GB2581/GB2581A	8
How to use the GB2581/GB2581A	9
Maintenance and Hydraulic Thread Preparation	10
Troubleshooting.....	11
Overhaul	12
Stroke Limiter & Relief Valve Installation/Removal.....	13
Parts Lists GB2581	14
Parts Lists GB2581A.....	15
Nose Assembly Selection Chart and Approved Accessories	16-24

GAGE BILT

DECLARATION OF CONFORMITY

MANUFACTURER: Gage Bilt Inc. 44766 Centre Ct., Clinton Twp., Michigan U.S.A. +1 (586-226-1500)

**WE DECLARE THAT THE EQUIPMENT SPECIFIED HEREIN CONFORMS
TO THE FOLLOWING DIRECTIVES AND STANDARDS**

Machinery Directive 2006/42/EC

EN12100-1 & EN12100-2

EN792-1:2000+A1

The Supply of Machinery (Safety) Regulations 2008

EU REPRESENTATIVE: Edgar Hausmann GmbH Förster-Busch-Str. 10 D-34346 Hann. Münden Germany

EQUIPMENT DESCRIPTION: GB2581 & GB2581A FASTENER INSTALLATION TOOL

This product specified above conforms to the above directives and standards.

SIGNATURE:



NAME: TIM SIMMONS
PRODUCT MANAGER
CLINTON TWP., MI U.S.A.
OCT 2022
+1(586) 226-1500



WARRANTY

Seller warrants that all goods covered by this catalog will conform to applicable specifications and will replace or repair, EXW our plant, any goods providing defective from faulty workmanship, or material, for 1 year from date of shipment.

Said warranty to remain in effect if, and only if, such goods are used in accordance with all instructions as to maintenance, operation and use, set forth in manuals and instruction sheets furnished by seller.

Sellers obligation under this warranty shall be limited to the repair or rework of the goods supplied or replacement thereof, at Seller's option, and in no case is to exceed the invoice value of said goods. Under no circumstances will the seller be liable for incidental or consequential damages or for damages incurred by the buyer or subsequent user in repairing or replacing defective goods or if the goods covered by this warranty are reworked or subjected to any type of additional processing.

This warranty is void if Seller is not notified in writing of any rejections or defects within 1 year after the receipt of the material by the customer.

THIS WARRANTY IS MADE IN LIEU OF ALL OTHER WARRANTIES EXPRESSED OR IMPLIED, INCLUDING MERCHANTABILITY.

DESCRIPTION



⚠ WARNING: Any other use is forbidden.

The GB2581 & GB2581(A) are hydraulic installation tools designed specifically for the efficient installation of blind, lockbolt and Magna-Grip® fasteners thru 3/8" diameter. It weighs 6.6 lbs. (2.99 kg) and can be operated in any position. It has a 1.000" (25.4 mm) fastener setting stroke and a rated pull load of 10,700 lbs. (47.59 kN) @ 7,400 psi. (510.2 bar).

The GB2581 (electric actuated) installation tool operates on hydraulic pressure developed by the GB947 power unit set at 7,400 psi. (510.2 bar) maximum PULL pressure and 3,200 psi (220.6 bar) maximum RETURN pressure. The tool comes equipped with 12 ft. (3.66 m) hoses and electric cord kit complete with quick disconnects.

The GB2581(A) (air actuated) installation tool operates on hydraulic pressure developed by the GB910 & GB912 Power units set at 7,400 psi (510.2 bar) maximum PULL pressure and 3,200 psi (220.6 bar) maximum RETURN pressure. The tool comes equipped with 12 ft. (3.66 m) of hydraulic hoses, couplings, air actuator and tubing.

NOSE ASSEMBLIES ARE NOT FURNISHED WITH THE INSTALLATION TOOL AND MUST BE ORDERED SEPARATELY. (See nose assembly selection chart on pg. 16).

ENVIRONMENTAL USE

⚠ WARNING: Do not operate in an explosive atmosphere.

The GB2581 and GB2581(A) can be operated between 0°F - 118°F (17.8°C - 47.8°C)

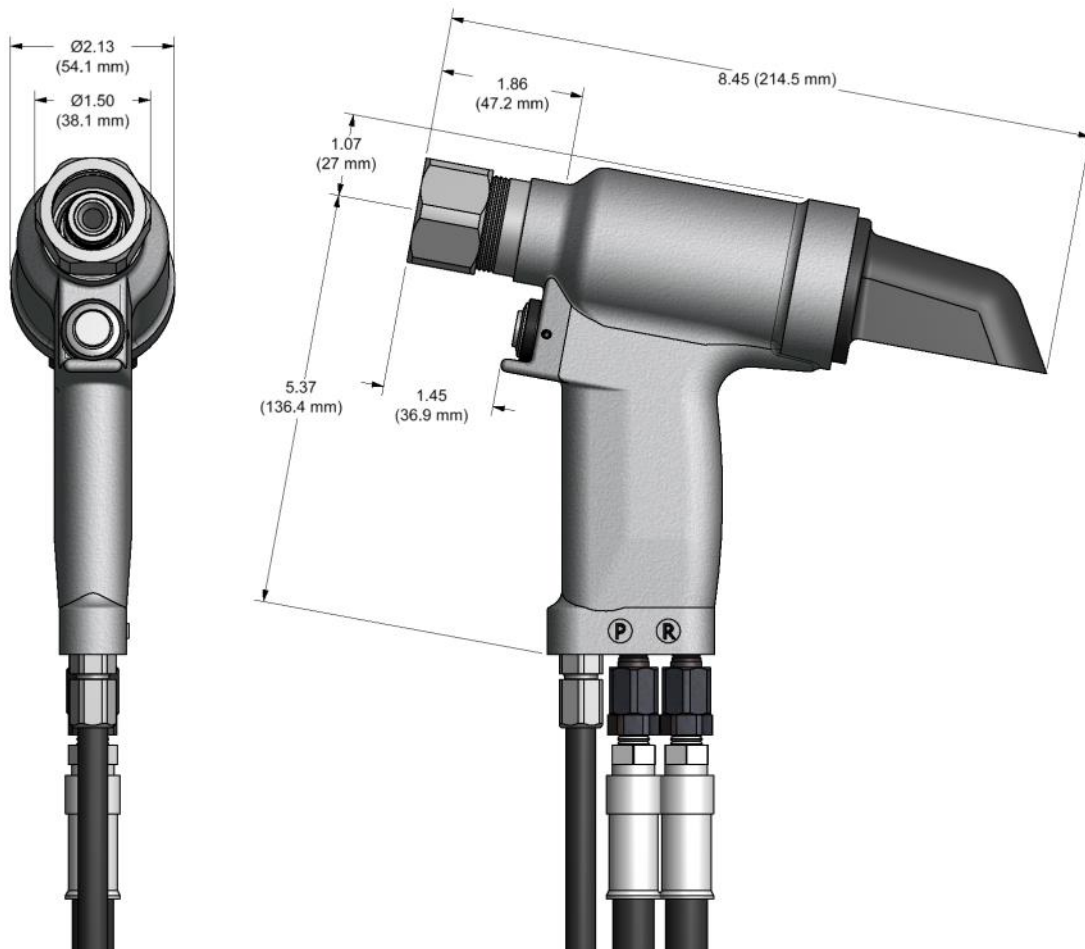

SPECIFICATIONS

Weight	- 6 lbs. 10 oz. (3.0 kg)
Hyd. pressure req'd	- 7,400 psi (510.2 bar) PULL 3,200 psi (220.6 bar) MAX RETURN
Hyd. Power Source	- GB947 or GB910/GB912 Powerunit or equivalent
Hydraulic Oil	- See power unit for hydraulic oil specifications
Setting stroke	- 1.000" (25.4 mm)
Rated pull load	- 10,700 lbs. (47.59 kN) @ 7,400 psi (510.2 bar)
Noise level	- 81.5 dB(A)
Vibration	- Tested – No hazards found.

DESCRIPTION OF FUNCTIONS



GB2581

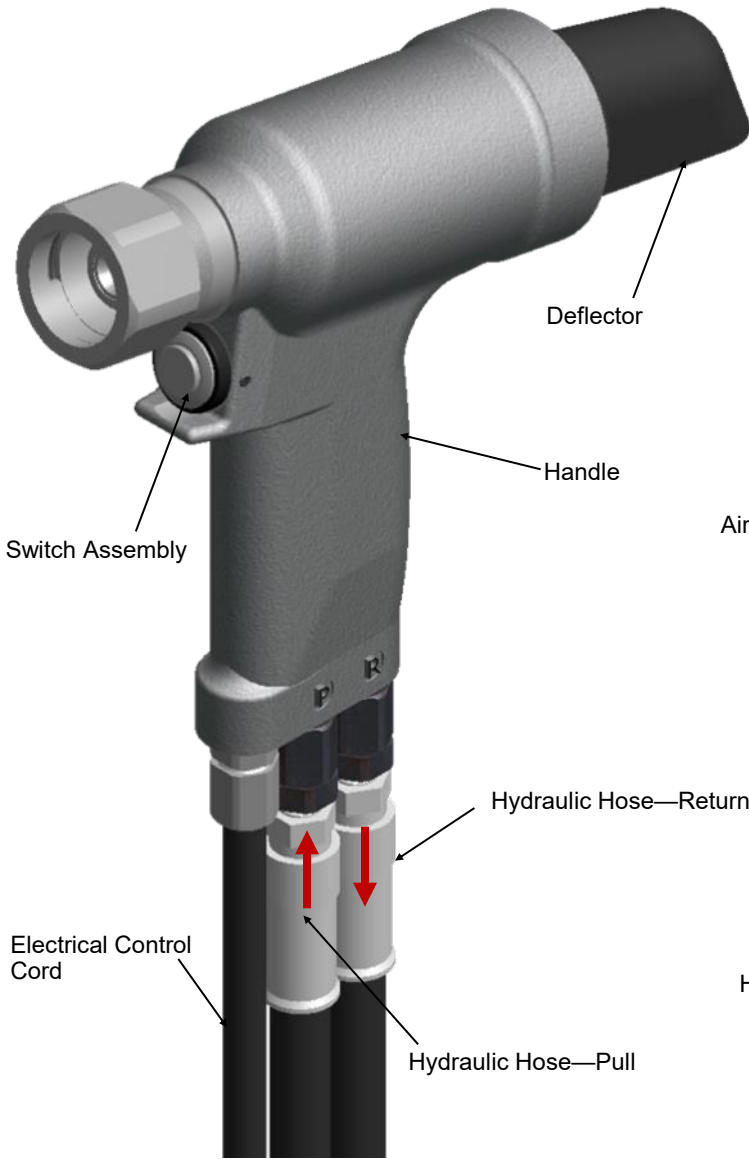

GB2581A

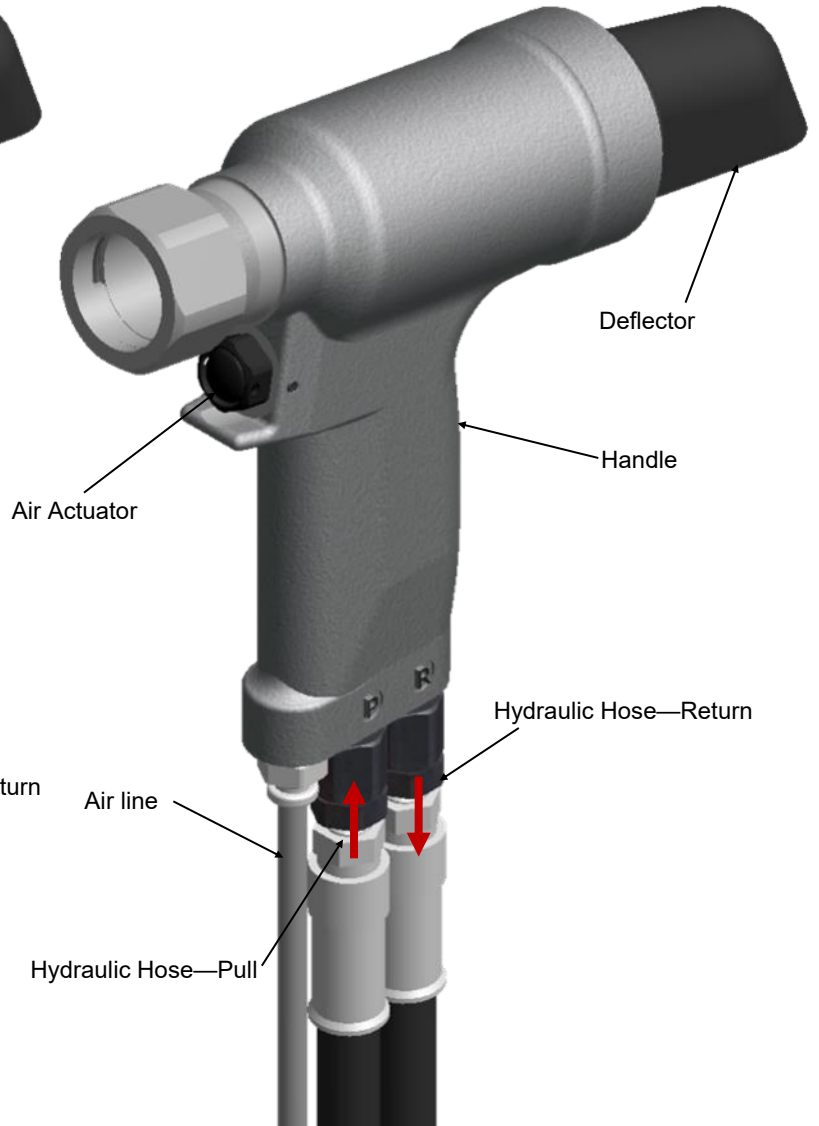

Images may not reflect actual tool



TERMS AND SYMBOLS



- Product complies with requirements



- Product complies with requirements



- Hearing protection and eye protection



- Read manual prior to using equipment



- Wear safety boots



WARNINGS - Must be understood to avoid severe personal injury.



CAUTIONS - show conditions that will damage equipment and/or structure.

Notes - are reminders of required procedures.

GENERAL SAFETY RULES:

1. For multiple hazards, read and understand the safety instructions before installing, operating, repairing, maintaining, changing accessories on, or working near the assembly power tool for non-threaded mechanical fasteners.
2. Only qualified and trained operators shall install, adjust or use the assembly power tool for non threaded mechanical fasteners.
3. Do not modify this assembly power tool for non-threaded mechanical fasteners. Modifications can reduce effectiveness of safety measures and increase the risks to the operator.
4. Do not discard safety instructions; give them to the operator.
5. Do not use assembly power tool for non-threaded mechanical fasteners if it has been damaged.
6. Tools shall be inspected monthly to verify all ratings and markings required are legible. The employer/user shall contact the manufacturer to obtain replacement marking labels when necessary.

ADDITIONAL SAFETY RULES FOR PNEUDRAULIC POWER TOOLS:

1. Air under pressure can cause severe injury.
2. Always shut off air supply, drain hose of air pressure and disconnect tool from air supply when not in use, before changing accessories or when making repairs.
3. Never direct air at yourself or anyone else.
4. Whipping hoses can cause severe injury. Always check for damage or loose hoses and fittings.
5. Cold air shall be directed away from hands.
6. Whenever universal twist couplings (claw couplings) are used, lock pins shall be installed and whip check safety cables shall be used to safeguard against possible hose-to-tool or hose-to-hose connection failure.
7. Do not exceed the maximum air pressure stated on the tool or manual.
8. Never carry an air tool by the hose.

PROJECTILE HAZARDS:

1. Disconnect the tool from the energy source when changing inserted tools/nose assemblies or accessories.
2. Be aware that failure of the workpiece, accessories, or the inserted tool/nose assembly itself can generate high-velocity projectiles.
3. Always wear impact resistant eye protection during operation of the tool.
4. Ensure that the workpiece is securely fixed.
5. Check that the means of protection from ejection of fastener and/or stem is in place and operative (such as the deflector, pintail collection bottle or catcher bag).
6. Forcible ejection of the mandrel from the front of the nose assembly is possible.

OPERATING HAZARDS:

1. Use of tool can expose the operator's hands to hazards, including crushing, impacts, cuts, abrasions and heat. Wear suitable gloves to protect hands.
2. Operators and maintenance personnel shall be physically able to handle the bulk, weight and power of the tool.
3. Hold the tool correctly; be ready to counteract normal or sudden movements and have both hands available.
4. Maintain a balanced body position and secure footing.
5. Release the start-and-stop device in the case of interruption of energy supply.
6. Use only lubricants recommended by the manufacturer.
7. Avoid unsuitable postures as it is likely for these positions not to allow counteracting of normal or unexpected movement of the tool.
8. If the tool is fixed to a suspension device, make sure that fixation is secure.
9. Beware of the risk of crushing or pinching if nose equipment is not fitted.
10. Due to the tool weight, it is recommended safety shoes be worn during operation.
11. It is recommended tool be operated not more than 50 out of every 60 minutes, where prolonged use is expected.

REPETITIVE MOTIONS HAZARDS:

1. When using the tool, the operator can experience discomfort in the hands, arms, shoulders, neck or other parts of the body.
2. While using the tool, the operator should adopt a comfortable posture while maintaining a secure footing and avoiding awkward or off balanced postures. The operator should change posture during extended tasks; this can help avoid discomfort and fatigue.
3. If the operator experiences symptoms such as persistent or recurring discomfort, pain, throbbing, aching, tingling, numbness, burning sensations or stiffness, these warning signs should not be ignored. The operator should tell the employer and consult a qualified health professional.

ACCESSORY HAZARDS:

1. Disconnect tool from energy supply before changing the nose assembly or accessory.
2. Use only sizes and types of accessories approved by the manufacturer. Do not use other types or sizes of accessories.

WORKPLACE HAZARDS:

1. Slips, trips and falls are major causes of workplace injury. Be aware of slippery surfaces caused by use of tool and also of trip hazards caused by the air line or hydraulic hose.
2. Proceed with care in unfamiliar surroundings. There could be hidden hazards, such as electricity or other utility lines.
3. The tool is not intended for use in potentially explosive atmospheres and is not insulated against contact with electrical power.
4. Ensure that there are no electrical cables, gas pipes, etc., which can cause a hazard if damaged by the tool.

NOISE HAZARDS:

1. Exposure to high noise levels can cause permanent, disabling hearing loss and other problems, such as tinnitus (ringing, buzzing, whistling or humming in the ears). Therefore, risk assessment and the implementation of appropriate controls for these hazards are essential.
2. Appropriate controls to reduce the risk may include actions such as damping materials to prevent workpieces from "ringing".
3. Always use hearing protection.
4. Operate and maintain the assembly power tool for non-threaded mechanical fasteners as recommended in the instruction handbook, to prevent an unnecessary increase in the noise level.
5. Select, maintain and replace the consumable/inserted tool as recommended in the instruction handbook, to prevent an unnecessary increase in noise.
6. If the power tool has a silencer, always ensure that it is in place and in good working order when the power tool is being operated.

VIBRATION HAZARDS:

1. Exposure to vibration can cause disabling damage to the nerves and blood supply of the hands and arms.
2. Wear warm clothing when working in cold conditions and keep your hands warm and dry.
3. If you experience numbness, tingling, pain or whitening of the skin in your fingers or hands, stop using the assembly power tool for non-threaded mechanical fasteners, tell your employer and consult a physician.
4. Support the weight of the tool in a stand, tensioner or balancer, because a lighter grip can then be used to support the tool.

PRINCIPLE OF OPERATION



When the tool is connected to a powerunit, operation is controlled by an switch assembly / air actuator in the handle. When the switch assembly is depressed, a directional valve in the powerunit directs oil to the front side of the piston assembly forcing it and the nose assembly collet rearward. This action causes the jaws to clamp onto the fastener pintail and pull the sheets together. The anvil is forced forward, swaging the collar into locking grooves of the fastener. Further force breaks the pintail off, approximately flush with the collar.

When the switch assembly / air actuator is released the directional valve reverses oil flow to the back of the piston assembly and pushes the nose assembly off of the swaged fastener. The pintail will eject from the deflector once next fastener is installed.

HYDRAULIC DIAGRAM

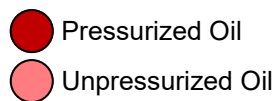
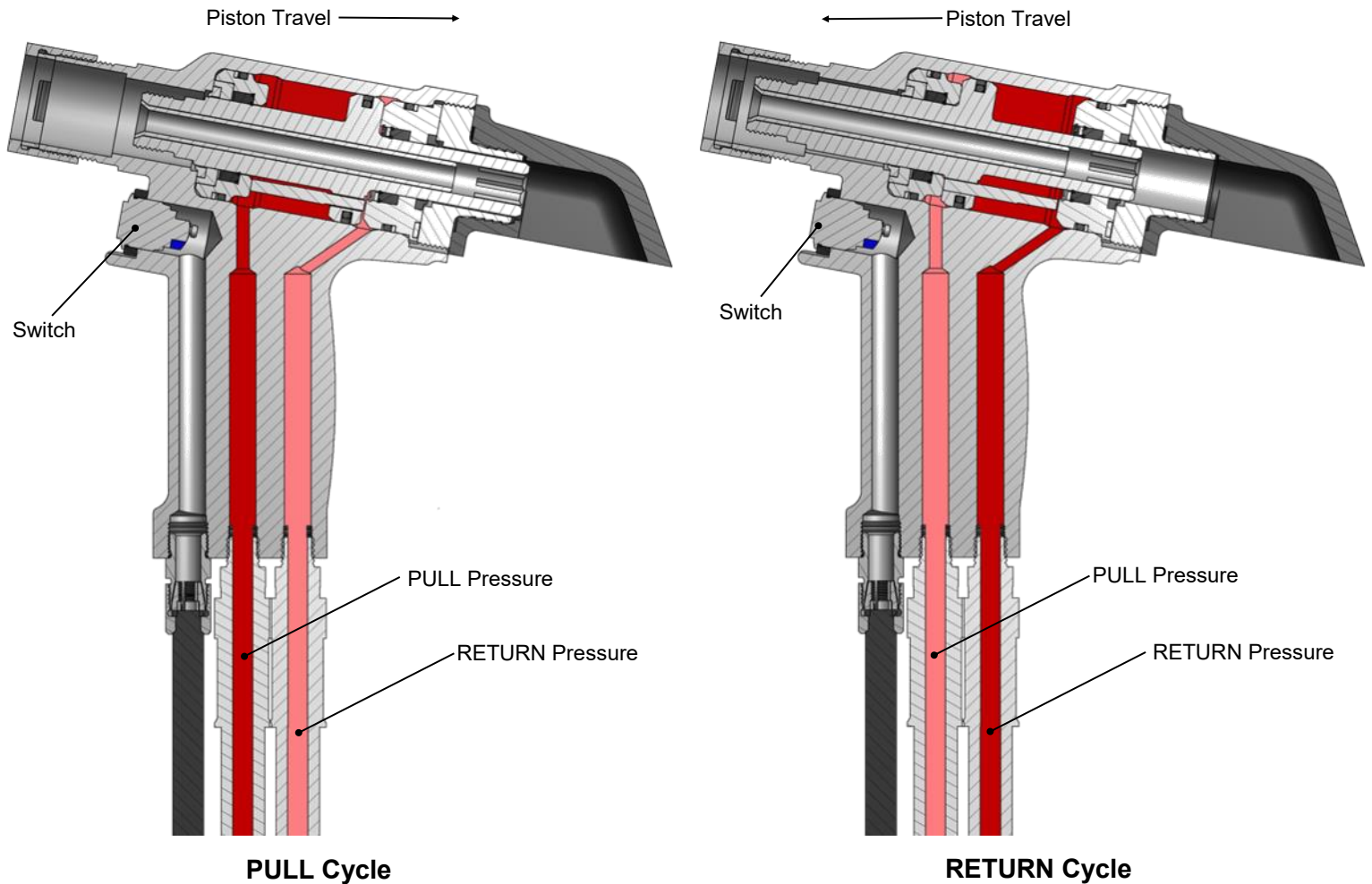

Images may not reflect actual tool

HOW TO SET-UP THE GB2581 / GB2581A



- ⚠ WARNING:** Only qualified and trained operators shall install, adjust or use the assembly power tool for non-threaded mechanical fasteners.
- ⚠ WARNING:** Operator **MUST** read and understand all warnings and cautions.
- ⚠ WARNING:** It is required that eye protection, hearing protection and safety boots be worn at all times while handling this equipment.
- ⚠ WARNING:** The users or the user's employer must assess specific risks that could be present before each use based on their application.
 - *Ensure there is adequate clearance for tool and operator's hands before proceeding. Keep fingers clear of any moving parts. Keep fingers clear from fasteners and installed materials. Severe personal injury may result.*
 - *Verify the air lines and/or hydraulic hoses are not a trip hazard.*
 - *Ensure that there are no electrical cables, gas pipes, etc., which can cause a hazard if damaged by the tool.*
 - *Verify that hydraulic hose fittings and couplings, air and electrical connections are secure before each use.*
- ⚠ WARNING:** Do not actuate fastener in the air. Personal injury from fastener ejecting may occur.
- ⚠ WARNING:** Do not carry from hoses or use as a hammer.
- ⚠ WARNING:** Do not use in explosive atmosphere.
- ⚠ WARNING:** Ensure air hose is securely connected to avoid possible hose whipping.
- ⚠ WARNING:** Always disconnect air supply, where applicable, when tool is not in use to prevent accidental start-up.
- ⚠ WARNING:** Do not exceed the maximum relief-valve setting stated on the tool and manual.
- ⚠ WARNING:** Do not operate when recommended pressures are exceeded as it could cause severe personal injury and or damage the equipment.
- ⚠ WARNING:** Use only Gage Bilt hydraulic hoses and couplings, or equivalent, rated for 10,000 psi. (689.5 bar) working pressure.
- ⚠ WARNING:** Do not operate this tool without deflector, pintail catcher bag or pintail collection bottle in place.
- ⚠ CAUTION:** Do not use beyond the design intent.

1. Set hydraulic power unit to the recommended pressure, 7,400 psi (510.2 bar) Max. for the pull and 3,200 psi (220.6 bar) Max. for the return. Gage Bilt pressure gage assembly (942280) (sold separately) is recommended to aid in this procedure. "See hydraulic power unit manual for correct procedure when adjusting pressures".

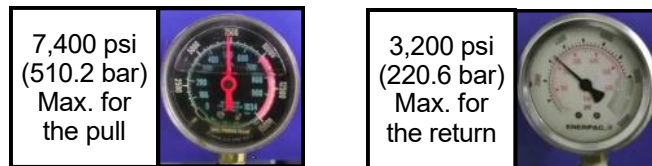

Images may not reflect actual p.s.i. settings

Note: Power units require a free flow of air for cooling purposes and must therefore be positioned in a well ventilated area free from hazardous fumes.

2. Attach deflector (258032) to rear of barbed retainer (258015) located on rear of cylinder-machined (258009). Rotate deflector (258032) away from operator and other persons working in the vicinity.
3. Turn off the hydraulic power unit. Wipe all couplers clean before connecting. Failure to do so can result in damage to the couplers and cause overheating. Connect hydraulic hoses then electric cord / air line to power supply.
4. Turn hydraulic power unit on and cycle tool five times by depressing actuator to ensure piston assembly (258111) is in the full forward position.
5. Disconnect hydraulic hoses (206119) and control cord assembly (480223) / air line (750154) from power supply.
6. Select proper Nose Assembly. (See nose assembly selection chart on pg. 16).
7. Hold piston assembly (258111) in place using a 3/8" allen wrench in the back of the piston assembly and screw collet securely on piston assembly.
8. Slide anvil over collet, slide retaining nut stop (480125) and retaining nut (480124) over anvil and tighten retaining nut (480124). (See proper data sheet for further instructions).
9. Re-connect control cord assembly (480223) / air line (750154) and hydraulic hoses (206119) to power supply.



- ⚠ WARNING:** Only qualified and trained operators shall install, adjust or use the assembly power tool for non-threaded mechanical fasteners.
- ⚠ WARNING:** Operator **MUST** read and understand all warnings and cautions.
- ⚠ WARNING:** It is required that eye protection, hearing protection and safety boots be worn at all times while handling this equipment.
- ⚠ WARNING:** The users or the user's employer must assess specific risks that could be present before each use based on their application.
 - *Ensure there is adequate clearance for tool and operator's hands before proceeding. Keep fingers clear of any moving parts. Keep fingers clear from fasteners and installed materials. Severe personal injury may result.*
 - *Verify the air lines and/or hydraulic hoses are not a trip hazard.*
 - *Ensure that there are no electrical cables, gas pipes, etc., which can cause a hazard if damaged by the tool.*
 - *Verify that hydraulic hose fittings and couplings, air and electrical connections are secure before each use.*
- ⚠ WARNING:** Do not actuate fastener in the air. Personal injury from fastener ejecting may occur.
- ⚠ WARNING:** Do not carry from hoses or use as a hammer.
- ⚠ WARNING:** Do not use in explosive atmosphere.
- ⚠ WARNING:** Ensure air hose is securely connected to avoid possible hose whipping.
- ⚠ WARNING:** Always disconnect air supply, where applicable, when tool is not in use to prevent accidental start-up.
- ⚠ WARNING:** Do not exceed the maximum relief-valve setting stated on the tool and manual.
- ⚠ WARNING:** Do not operate when recommended pressures are exceeded as it could cause severe personal injury and or damage the equipment.
- ⚠ WARNING:** Use only Gage Bilt hydraulic hoses and couplings, or equivalent, rated for 10,000 psi. (689.5 bar) working pressure.
- ⚠ WARNING:** Do not operate this tool without deflector, pintail catcher bag or pintail collection bottle in place.
- ⚠ CAUTION:** Do not use beyond the design intent.

Lockbolts

1. Insert fastener through the work piece.



2. Slide collar over fastener.

Note: Always hold tool so pulling head is perpendicular to surface of material in which fastener is being installed. Exert firm pressure against fastener during installation.



3. Insert fastener into nose assembly.



4. Press actuator to start cycle.
5. Release actuator as soon as fastener breaks.
6. Repeat steps 1 - 5.

Blind Fasteners

1. Insert fastener.

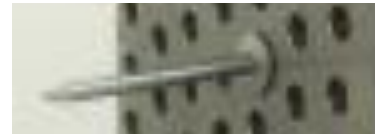

2. Insert fastener into nose assembly.

Note: Always hold tool so pulling head is perpendicular to surface of material in which fastener is being installed. Exert firm pressure against fastener during installation.



3. Press actuator to start cycle.



4. Release actuator as soon as fastener breaks.
5. Repeat steps 1 - 4.

Images may not reflect actual tool or fastener

DAILY MAINTENANCE



- ⚠ WARNING:** Tool must be maintained in a safe working condition at all times and examined on a daily basis for damage or wear. Any repair must be done by qualified personnel trained on Gage Bilt procedures.
- ⚠ WARNING:** Excessive contact with hydraulic oil and lubricants must be avoided.
- ⚠ WARNING:** Maintenance personnel **MUST** read and understand all warnings and cautions.
- ⚠ WARNING:** Disconnect tool from its power source before performing maintenance, cleaning or when replacing worn or damaged components. Severe personal injury may occur if power source is not disconnected.
- ⚠ WARNING:** Read Material Safety Data Sheet documents for all applicable materials.

Note:

- Dispose of hydraulic oil in accordance with manufacture safety datasheet.
- All tool materials are recyclable except rubber o’rings, seals and wipers.
- Gage Bilt does not recommend using a pneumatic lubricator or adding pneumatic oil to the air inlet on our tools or powerunits.

The performance of any tool depends upon good maintenance practices. Following these minimal requirements daily will extend the life of your tool.

- * Only use a clean dry air supply set at 90 - 100 p.s.i. (6.2 - 6.9 bar) Max. equipped with a filter-regulator to prevent wear.
- * Check tool and nose assembly for damage. (Replace/Repair if necessary). See Overhaul pg. 12 for tool repair.
- * Inspect all hoses and couplings for wear, damage and leaks. Replace/Repair if necessary. (See *hydraulic thread preparation below*).
- * Verify that hydraulic hose fittings and couplings, air and electrical connections are secure. Tighten, Replace or Repair if necessary. (See *hydraulic thread preparation below*).
- * Cycle the tool several times to assure there are no leaks during use.
- * Only use a hydraulic power source equipped with relief valves and pressures set within specific limits. (See required max pressure for pull and return pg. 8).
- * Keep hydraulic system free of dirt. Avoid letting couplers contact a dirty floor.
- * Do not use as a hammer to force fasteners into holes or otherwise abuse tool.
- * Proper care by operators is necessary in maintaining full productivity and reducing downtime.
- * Keep nose assemblies, especially jaws, clean and free of chips and debris. Lube jaws and collet surfaces that jaws ride on with light machine oil on a daily basis.
- * All Screwed End Caps, Base Covers, Air Fittings, Air Actuators, Screws and Nose Assemblies are to be examined at the end of each working shift to check that they are secure.

SEE TROUBLESHOOTING (PG. 11) AND OVERHAUL (PG. 12) FOR FURTHER GUIDANCE.

HYDRAULIC THREAD PREPARATION

IMPORTANT: Be sure to use thread sealant on all hydraulic fittings, Loctite® 545 or equivalent or a non-hardening Teflon® thread compound such as Slic-tite®. Tighten until fitting feels snug and then continue to tighten 1/2 to 1 full turn. **CAUTION:** Over tightening can easily distort the threads. DO NOT USE TEFLON® TAPE. **CAUTION:** Teflon® tape is an excellent thread sealer, however, if it is not properly applied, pieces of Teflon® may enter the hydraulic system and cause a malfunction or damage.

CLEANING AND LUBRICATING PROCEDURE

Daily cleaning and lubrication of nose assembly will greatly reduce downtime and increase life of components. Using sewing machine oil, or an equivalent cleaner/lubricant, follow instructions below.

CLEANING

Clean nose assembly daily or as often as needed.

1. Dip into mineral spirits or similar solvent to clean jaws and wash away metal chips and debris. DO NOT allow jaws to come in contact with other solvents. DO NOT let jaws soak. Dry jaws immediately.
2. Disassemble nose assembly and use a sharp “pick” to remove embedded particles from grooves of jaws.

LUBRICATING

Lubricate nose assembly after each cleaning and as often as needed.

1. Disconnect tool vacuum line (if equipped).
2. Point nose assembly into oil as shown.
3. Cycle tool 8 - 10 times and wipe dry.

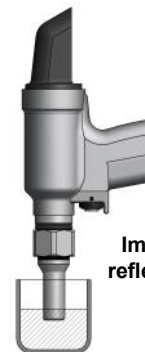

Image may not reflect actual tool

TORQUE SPECIFICATIONS

Socket Head Cap Screw (406030) = 20 inch lbs. (2.26 Nm).
Set Screw (401731) = 20 inch lbs. (2.26 Nm).

TROUBLESHOOTING



Providing all maintenance conditions have been met, follow this systematic approach to diagnosis.

1. **NO OPERATION WHEN SWITCH ASSEMBLY (260025) OR AIR ACTUATOR ASSEMBLY (240123) IS DEPRESSED.**
 - a) Check Powerunit power source.
 - b) Control cord may be loose or damaged.
 - c) Faulty switch assembly. Replace.
 - d) Check hydraulic couplings; repair or replace.
 - e) Relief valve not installed in tool.
2. **SLOW OR PARTIAL OPERATION WHEN SWITCH ASSEMBLY (260025) OR AIR ACTUATOR ASSEMBLY (240123) IS DEPRESSED.**
 - a) Low hydraulic pressure. Check powerunit, adjust.
 - b) Glyd Ring Assembly (406180) on Cylinder-machined (258009) could be worn or damaged. Replace.
 - c) Excessive wear or scoring on moving parts. Check and replace faulty parts.
 - d) Check hydraulic couplings; repair or replace.
3. **TOOL OPERATES IN REVERSE.**
 - a) Tool stops in back position. Hydraulic hoses are reversed. Correct.
4. **HYDRAULIC OIL OVERHEATS.**
 - a) Powerunit motor rotation reversed. Electrical connections reversed. See powerunit instruction manual.
 - b) Restrictions in either hydraulic lines, hoses or couplings. Check and tighten, clean or replace. (*See hydraulic thread preparation pg. 10*).
5. **OIL LEAKAGE.**
 - a) Hydraulic oil leaks from connections. Tighten threaded connections. Do not use Teflon® tape. (*See hydraulic thread preparation pg. 10*).
 - b) Oil leaks from tool. Determine source of leak and replace worn or defective o'rings and back-up rings.
 - c) Relief valve installed incorrectly.
6. **PINTAIL GROOVES STRIPPED DURING PULL STROKE.**
 - a) Nose Assembly must be pushed onto fastener fully.
 - b) Chips may have collected in chuck jaws. Disassemble nose assembly, clean jaws in mineral spirits using a sharp pointed object.
 - c) Chuck jaws may be worn or damaged. Replace.
 - d) Pintail too short for jaws to properly grip. Select proper grip length fastener.
 - e) Excessive gap between sheets. Reduce gap before attempting to install fastener.
7. **NOSE ASSEMBLY WON'T ACCEPT FASTENER PINTAIL.**
 - a) Spent fastener stem may be jammed in pulling head. Disassemble and check for worn or broken parts in nose assembly. Replace defective parts and clean before reassembling.
8. **PINTAIL OF FASTENER FAILS TO BREAK.**
 - a) Improper tool operation.
 - b) Pull grooves on fastener stripped.
 - c) Pull pressure too low.
 - d) Worn relief valve.



- ⚠ WARNING:** Only qualified and trained personnel shall perform overhaul.
- ⚠ WARNING:** Personnel must read and understand all warnings and cautions.
- ⚠ WARNING:** Tool must be maintained in a safe working condition at all times and examined on a daily basis for damage or wear. Any repair must be done by qualified personnel trained on Gage Bilt procedures.
- ⚠ WARNING:** Disconnect tool from its power source before performing overhaul. Severe personal injury may occur if power source is not disconnected.
- ⚠ WARNING:** Excessive contact with hydraulic oil and lubricants must be avoided. (See safety data sheet documents for all applicable materials).
- ⚠ WARNING:** When operating, repairing or overhauling tool, wear approved eye protection. Do not look in front of tool or rear of tool when installing fastener.
- ⚠ WARNING:** Use only Gage Bilt hydraulic hoses and couplings, or equivalent, rated for 10,000 psi. (689.5 bar) working pressure.
- ⚠ WARNING:** Ensure air hose is securely connected to avoid possible hose whipping. (Air Actuated Tools only).
- ⚠ WARNING:** Do not exceed the maximum relief-valve setting stated on the tool and manual.
- ⚠ WARNING:** Relief valve must be installed with four flats towards the rear of the cylinder.

Note:

- Dispose of hydraulic oil in accordance with manufacture safety datasheet.
- All tool materials are recyclable except rubber o'rings, seals and wipers.
- Gage Bilt does not recommend using a pneumatic lubricator or adding pneumatic oil to the air inlet on our tools or powerunits.
- *Use of SERVICE KIT (GB2581KS), contains a complete set of o'rings, back-up rings and screws, can achieve a complete overhaul.*

If a tool is performing poorly or leaking, a complete overhaul may be necessary.

Perform overhaul in a clean, well lit area using care not to scratch or nick any smooth surface that comes in contact with an o'ring. Use of Lubriplate® #630-AA (Gage Bilt part no. 402723) or equivalent during reassembly to prevent tearing or distorting of o'rings.

1. Disconnect control cord assembly (480223) / air line (750154) from power supply.
2. Disconnect hydraulic hose (206119) from power supply.
3. Remove hydraulic coupler-male (585047) & hydraulic coupler-female (585038) from hydraulic hose (206119) and drain into a container.
4. Remove retaining nut (480124), retaining nut stop (480125), and nose assembly.
5. Push piston assembly (262806) rearward until remaining hydraulic oil is drained.
6. Remove deflector (258032), socket head cap screw (406030), barbed retainer (258015), wiper (405991), locator (582127) and rear gland assembly (258017).
7. Push piston assembly (258111) rearward until it is out of cylinder assembly (262808).
8. Remove front gland assembly (258114), polyseal (406160), wiper housing (258007) and wiper (405894).
9. Remove all O'rings, Back-up rings, Wipers, Polyseals and Glyd Rings. Clean parts in mineral spirits or other o'ring compatible solvent being sure to clean o'ring grooves. Inspect components for scoring, excessive wear or damage.
10. Reassembly sequence is opposite of disassembly. Be sure relative positions of o'rings and back-up rings are as shown in exploded view and part list.

Coat hose fitting threads with a non-hardening Teflon thread compound such as Slic-tite®. DO NOT USE TEFLON® TAPE. (See hydraulic thread preparation pg. 10).

Apply hot glue to wire connections of the switch assembly (260025) to ensure wires DO NOT contact each other or handle assembly. (Electric actuated installation tool GB2581 only).

TOOL DISPOSAL

1. When tool life is met, drain hydraulic oil from tool and dispose of the hydraulic oil in accordance with the safety datasheet.
2. Disassemble tool and remove all rubber o'rings, seals, wipers and hydraulic hoses. All tool materials are recyclable except rubber o'rings, seals, wipers and hydraulic hoses. Dispose of rubber materials in accordance with the material safety datasheet.

STROKE LIMITER & RELIEF VALVE - INSTALLATION & REMOVAL



- ⚠ WARNING:** Disconnect the tool from power source when adding or removing stroke limiters and relief valves.
- ⚠ WARNING:** Ensure flat on stroke limiter clears the installed relief valve or damage to tool or personal injury can occur.

1. Insert relief valve into piston with 4 flats facing rear of tool (see images below). DO NOT insert into piston with 4 flats facing the front of tool or damage to the tool or personal injury can occur.

Stroke limiters and relief valves are used when a shorter tool stroke is required. Refer to nose assembly data sheet to see if a stroke limiter is needed. Stroke limiters and relief valves are sold separately.

If required, stroke limiters are designed for the protection of the operator and equipment. Failure to operate tool without a stroke limiter, if required, will result in damage to the nose assembly or tool and may result in personal injury. If you are unsure your nose assembly requires a stroke limiter, contact Gage Bilt.

- To reduce stroke see overhaul (#1 thru #7) on pg. 12 to remove piston assembly then refer to instructions and illustrations below and see warnings above.
- To reduce stroke to .750" 258153 stroke limiter & 258156 relief valve must be used. (Sold separately):**
 - Remove the relief valve that comes with the tool (258119 = electric actuated / 258021 = air actuated) from the piston assembly (258111).
 - Install 258156 relief valve (sold separately) into relief valve hole on 258111 piston assembly. The end with 4 flats needs to face rear of the tool. Then install 258153 stroke limiter (sold separately) over rear of 258111 piston assembly ensuring flat on 258153 stroke limiter is facing the 4 flats on 258156 relief valve. Note positions and locations shown below.
- To reduce stroke to .500" 258152 stroke limiter & 258157 relief valve must be used. (Sold separately):**
 - Remove the relief valve that comes with the tool (258119 = electric actuated / 258021 = air actuated) from the piston assembly (258111).
 - Install 258157 relief valve (sold separately) into relief valve hole on 258111 piston assembly. The end with 4 flats needs to face rear of the tool. Then install 258152 stroke limiter (sold separately) over rear of 258111 piston assembly ensuring flat on 258152 stroke limiter is facing the 4 flats on 258157 relief valve. Note positions and locations shown below.

Note: See adapters (353206-1 & 745208) data sheets for complete instructions on how to assemble to an installation tool.

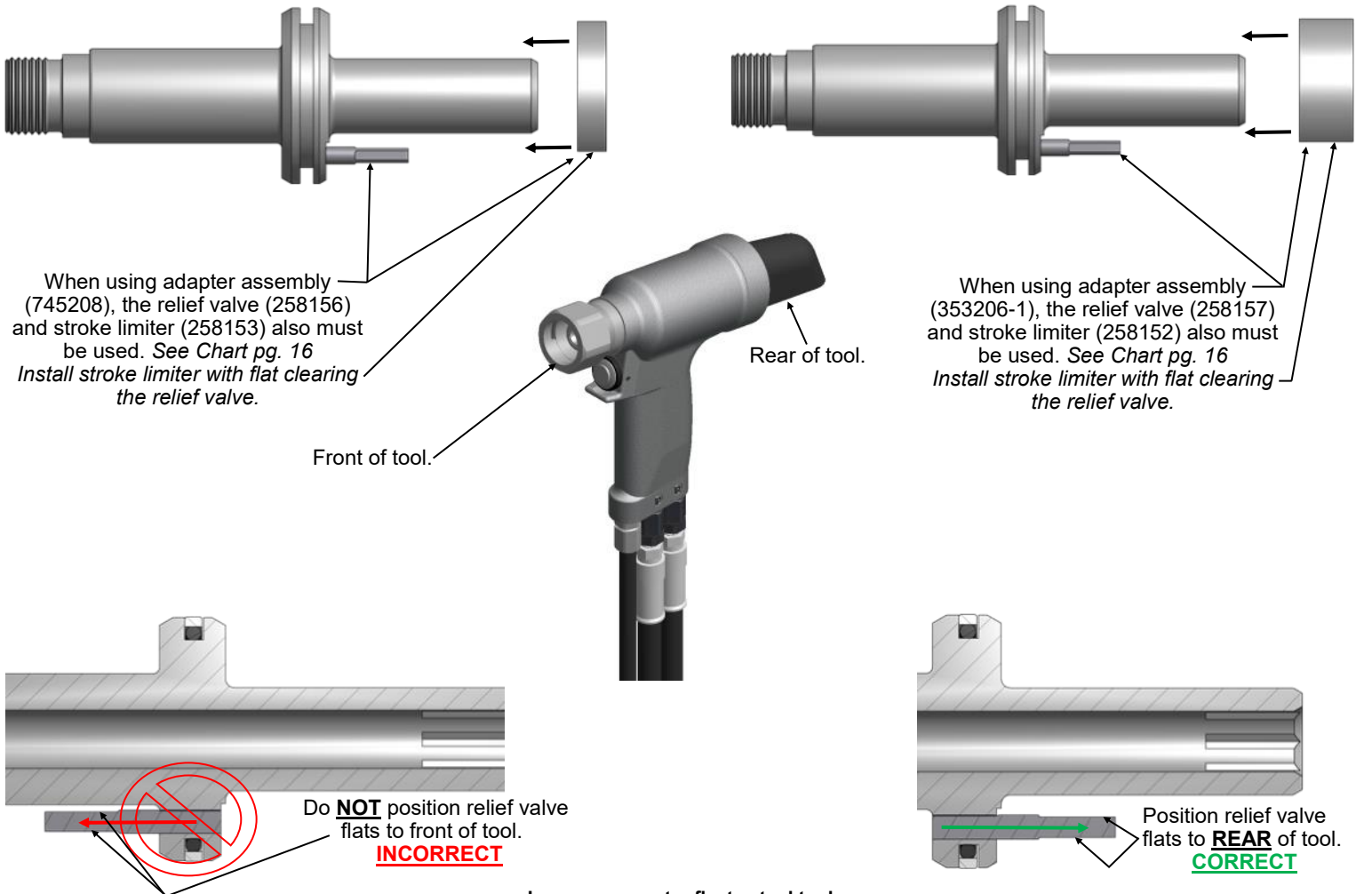

Images may not reflect actual tool

GB2581- PARTS LIST

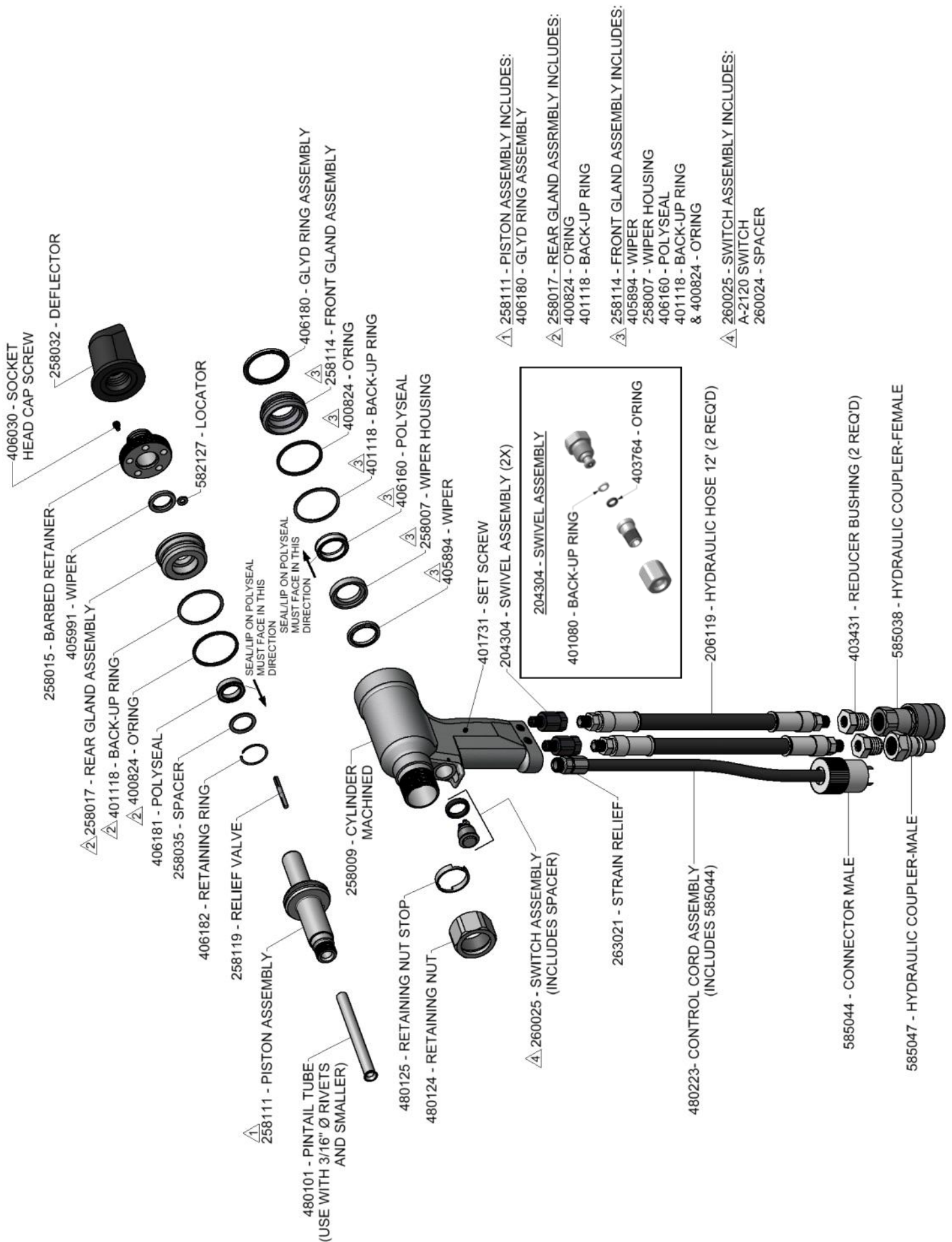

GB2581A- PARTS LIST

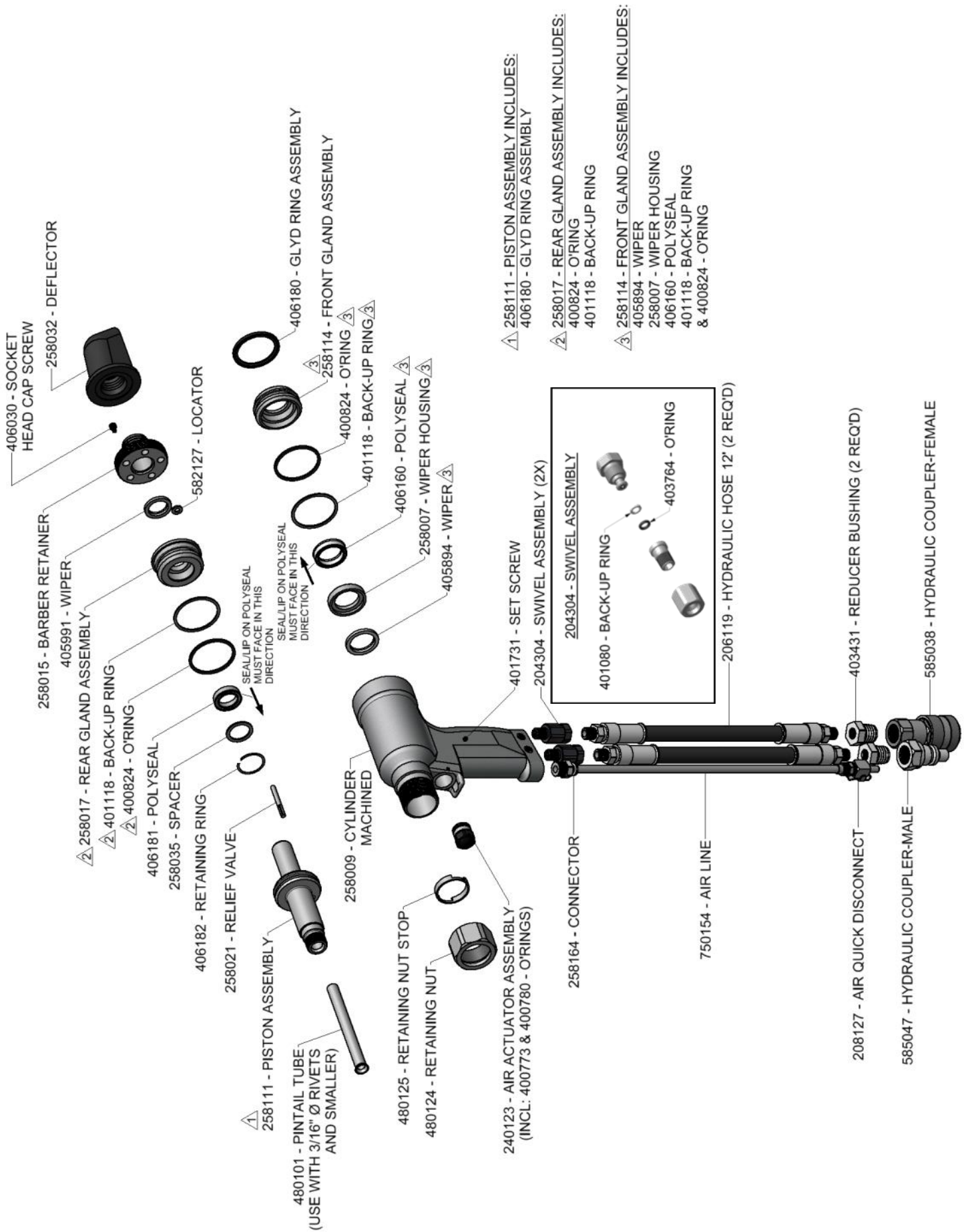

GB2581/GB2581(A) ACCESSORIES



Approved for use on Gage Bilt CE installation tools and/or other manufacturer's CE approved tools of similar design.
(Sold Separately)

GRIP GAGES

Grip Gage #269G3

For CHERRYMAX® and CHERRYLOCK® fasteners
(Sold Separately)



Grip Gage #GB105093

For NAS LOCKBOLTS and blind fasteners
(Sold Separately)



Adapter Assembly #353206-1

Adapts all offset "OSSG" series noses
(Sold Separately)

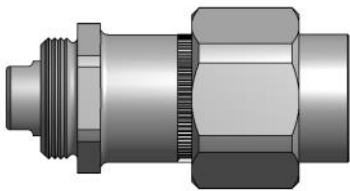

Adapter Assembly #745208

Adapts all offset 208 series noses.
(Sold Separately)

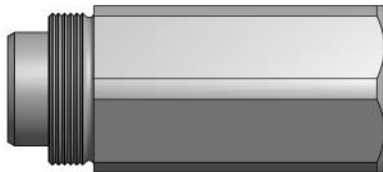

Gage Bilt also supplies pin & collar swage inspection gages to certify correct swage installation
(Sold Separately)

XX-25OSSG, XX-30OSSG & XX-34OSSG, Offset Nose Assemblies are supplied with a one-piece Super Grip Jaw Assembly for dry applications.

For wet applications where sealant is used, XX-25OS, XX-30OS & XX-34OS Offset Nose Assemblies may be ordered. The "OS" designates that the Offset Nose Assembly will come with loose Jaws, Follower, Spring and Locator for easier cleaning.

Please note *this only applies* to cartridge style Offset Noses listed on chart above.

NOSE ASSEMBLY SELECTION CHART

STRAIGHT
(Sold Separately)



***OFFSET**
(Sold Separately)



FASTENER	DIA.	STRAIGHT		*OFFSET	
ASP® ASP 2, ASP PF, ASP 2 F, ASP 2 LC, ASP 4 FF, ASP FF, ASP F, ASP-LC and MAF	13/64 17/64 21/64	ASP06-745C-23 ASP08-745B-23 ASP10-755-23	ASP06-745C-48 ASP08-745B-48 ASP10-755-48	ASP06-27OSSG ASP08-27OSSG ASP10-27OSSG	ASP06-37OSSG ASP08-37OSSG ASP10-37OSSG
BOM®	1/4 5/16 3/8	BOM08-755A-23 BOM10-756-26 **BOM12-756A-26			
COMMERCIAL LOCKBOLTS C6L®, AVDELOK®	1/4 5/16 3/8	NAS06-2581-12 NAS06-2581-23 NAS08-2581-12 NAS08-2581-23 LB10-745C-26 LB12-756-26	NAS06-2581-48 NAS08-2581-48 NAS10-2581-23 NAS12-756-48	NAS06-25OSSG NAS06-34OSSG NAS08-25OSSG NAS08-34OSSG NAS10-208C-31 NAS12-208A-31	NAS06-30OSSG NAS08-30OSSG
CONTAINER BOLT(R 12) HLPP, HLPFM, HLPPE, HLPFS HLPSC & HLPSP	3/8	HT12-756-23			
FLOOR BOLT	5/16	FT10-353A-28			
LGP® LOCKBOLT	5/32	LGP05-2581-12 LGP05-2581-48	LGP05-2581-23	LGP05-25OSSG LGP05-34OSSG	LGP05-30OSSG
LGPL2SC-V BACB30VM LGPL18SC-V BACB30XT LGPL4SC-V ABS0548 LGPL2SP-V BACB30VN LGPL4SP-V ASNA2392 LGPL8SC-V BACB30WD LGPL9SC-V BACB30WB LGPL9SP-V BACB30VY BACB31N BACB31P	3/16 7/32 1/4 5/16 3/8	LGP06-2581-12 LGP06-2581-48 LGP07-2581-12 LGP07-755-48 LGP08-2581-12 LGP08-2581-48 LGP10-2581-12 LGP10-2581-48 LGP12-745B-12 LGP12-756-48	LGP06-2581-23 LGP07-755-23 LGP08-2581-23 LGP10-2581-23 LGP12-756-26	LGP06-25OSSG LGP06-34OSSG LGP07-25OSSG LGP07-34OSSG LGP08-25OSSG LGP08-34OSSG LGP10-208C-31	LGP06-30OSSG LGP07-30OSSG LGP08-30OSSG
NAS and GP® SHEAR/TENSION LOCKBOLTS	5/32 3/16	NASS05-2581-12 NASS05-2581-23 NASS05-2581-48 NAS06-2581-12 NAS06-2581-48 NAS08-2581-12 NAS08-2581-48 NAS10-2581-12 NAS10-2581-48 NAS12-745B-12 NAS12-756-48	NAST05-2581-12 NAST05-2581-23 NAST05-2581-48 NAS06-2581-23	NASS05-25OSSG NASS05-30OSSG NASS05-34OSSG NAS06-25OSSG NAS06-34OSSG NAS08-25OSSG NAS08-34OSSG NAS10-208C-31 NAS12-208A-31	NAST05-20OSSG NAST05-30OSSG NAST05-34OSSG NAS06-30OSSG NAS08-30OSSG
BACB30TY BACB30UA BACB30TZ BACB30UB BACB30DY BACB30GX BACB30DX BACB30GP BACB30GO BACB30GY BACB30GW	1/4 5/16 3/8				
MAGNA-GRIP®, MULTI-GRIP, MAXLOK® LOCKBOLTS	3/16 1/4 5/16 3/8	MG06-745-48 MG08-745-48 MG10-756-28 MG12-756-28			
MAGNA-LOK®, MAGNA-BULB® & HEMLOK® COUNTER SUNK AND PROTRUDING HEAD SERRATED STEM STRUCTURAL RIVETS	3/8	MGL12-353C-28			
OVERSIZE STRUCTURAL RIVET	1/4 5/16 3/8	OS08-745-48 OS10-756-26 OS12-756A-26	OS10-756-48 OS12-756A-48		
MS90353S & U / MS90354S & U MS21140S & U / MS21141S & U MAXIBOLT®, BACB30Y, YU, & YT CR7000 SERIES	5/32 3/16 1/4	SB05-745C-23 SB06-745B-23 SB08-755-23	SB05-745C-48 SB06-745B-48 SB08-755-48	SB05-27OSSG SB06-27OSSG SB08-27OSSG	SB05-37OSSG SB06-37OSSG SB08-37OSSG
BLIND BOLT (SINGLE ACTION) WITH OR W/OUT DRIVE WASHER	5/16 3/8	SB10-756-28 SB12-756-28	SB10-756-48 SB12-756-48		
MS90353S & U / MS90354S & U MS21140S & U / MS21141S & U MAXIBOLT®, BACB30Y, YU, & YT CR7000 SERIES	5/32 3/16 1/4	UBB05-745C-23 UBB06-745B-23 UBB08-755-23	UBB05-745C-48 UBB06-745B-48 UBB08-755-48	UBB05-27OSSG UBB06-27OSSG UBB08-27OSSG	UBB05-37OSSG UBB06-37OSSG UBB08-37OSSG
BLIND BOLT (SINGLE ACTION) WITH DRIVE WASHER	5/16 3/8	UBB10-756-28 UBB12-756-28	UBB10-756-48 UBB12-756-48		

ASP®, BOM®, C6L®, M LGR®, M GP®, MAGNA-GRIP®, MAGNA-LOK®, MAGNA-BULB®, UNIMATIC® AND LGP® ARE REGISTERED TRADEMARKS OF HOWMET AEROSPACE. AVDELOK®, HEMLOK® AND MAXLOK® ARE REGISTERED TRADEMARKS OF AVDEL UK LIMITED. MAXI-BOLT® IS A REGISTERED TRADEMARK OF CHERRY AEROSPACE.

GAGE BILT CERTIFIES THE GB2581 WILL INSTANTLY THE ABOVE FASTENERS

*ALL OFFSET OSSG SERIES NOSES REQUIRE 353206-1 ADAPTER WITH 258152 STROKE LIMITER AND 258157 RELIEF VALVE.
*ALL OFFSET 208 SERIES NOSES REQUIRE 745208 ADAPTER WITH 258153 STROKE LIMITER AND 258156 RELIEF VALVE.

** Repair Only

NOTE: THE LAST 2 DIGITS OF THE NOSE ASSEMBLY REPRESENTS THE LENGTH THE NOSE EXTENDS FROM THE TOOL I.E. -20 = 2.0 INCHES

GB2581/GB2581A ACCESSORIES Cont.



Approved for use on Gage Bilt CE installation tools and/or other manufacturer's CE approved tools of similar design.
(Sold Separately)

Relief Valve

#258157 for .500" tool stroke

Required with stroke limiter (258152)
when used with adapter (353206-1) for
OSSG series noses. See Chart pg. 16
(Sold Separately)



Relief Valve

#258156 for .750" tool stroke

Required with stroke limiter (258153)
when used with adapter (745208) for
208 series noses. See Chart pg. 16
(Sold Separately)



Stroke Limiter

#258152 for .500 tool stroke

Required with Relief Valve (258157) used
with adapter (353206-1) for OSSG series
noses. See Chart pg. 16
(Sold Separately)



Stroke Limiter

#258153 for .750" tool stroke

Required with Relief Valve (258156) used
with adapter (745208) for 208 series noses.
See Chart pg. 16
(Sold Separately)



GB2581/GB2581A ACCESSORIES Cont.

Approved for use on Gage Bilt CE installation tools and/or other manufacturer's CE approved tools of similar design.
(Sold Separately)



GB947 ELECTRIC POWERUNIT

(Sold Separately)



The GB947 Hydraulic Powerunit is a light-weight, portable power source designed to operate on a wide range of hydraulic installation tools. The unit is electrically powered and delivers up to 10,000 psi (689.48 bar) working pressure with simple adjustable hydraulic outputs. The 24 volt remote control circuit, in the installation equipment, controls the pump output directional valve. The GB947 Hydraulic Powerunit is available in 115 volt or 230* volt, single phase, alternating current. Output pressures as shipped are: PULL 5400 - 5700 psi, RETURN 2200 - 2400 psi.

The GB947 Hydraulic Powerunit is available separately or in kits including hydraulic quick-disconnect couplers, electrical connectors and hose cord kits in various lengths.

GB947-12 includes the GB947 and 12 ft. (3.7m) Hose Kit, part #940701

GB947-26 includes the GB947 and 26 ft. (7.9m) Hose Kit, part #940705

GB947-38 includes the GB947 and 38 ft. (11.6m) Hose Kit, part #940709

GB947-52 includes the GB947 and 52 ft. (15.8m) Hose Kit, part #940714

Images may not reflect actual tools

GB2581/GB2581A ACCESSORIES Cont.



Approved for use on Gage Bilt CE installation tools and/or other manufacturer's CE approved tools of similar design.
(Sold Separately)

GB910 HYDRAULIC POWERUNIT

(Sold Separately)



The GB910 Hydraulic Powerunit is a portable power source designed to operate a wide range of hydraulic installation tools. The unit air powered, air actuated and delivers up to 10,000 psi (689.48 bar) working pressure. The actuator on the installation tool remotely controls the hydraulic oil directional flow. The unit consists of a two position air hydraulic pump, four way control valve and relief valve mounted on the reservoir.

The GB910 Hydraulic Powerunit is available separately or in kits including hydraulic quick-disconnect couplers, air connectors, air lines and hydraulic hoses in various lengths.

GB910-12 includes the GB910 and 12 ft. (3.7m) Hose Kit-Air, part #910701

GB910-26 includes the GB910 and 26 ft. (7.9m) Hose Kit-Air, part #910705

GB910-38 includes the GB910 and 38 ft. (11.6m) Hose Kit-Air, part #910709

GB910-52 includes the GB910 and 52 ft. (15.8m) Hose Kit-Air, part #910714

GB912 HYDRAULIC POWERUNIT

(Sold Separately)

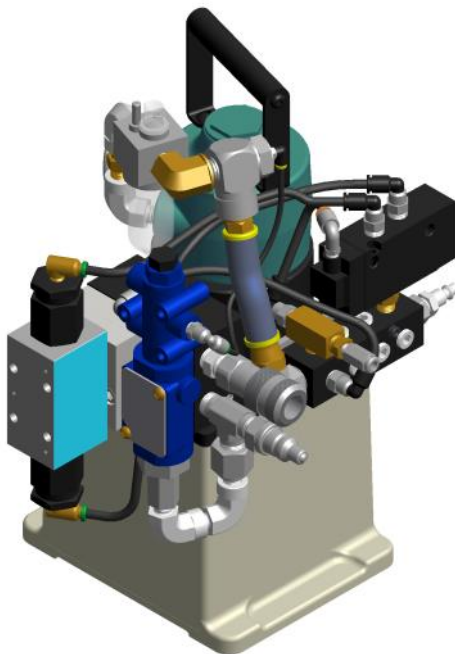

GB912D HYDRAULIC POWERUNIT

(Sold Separately)

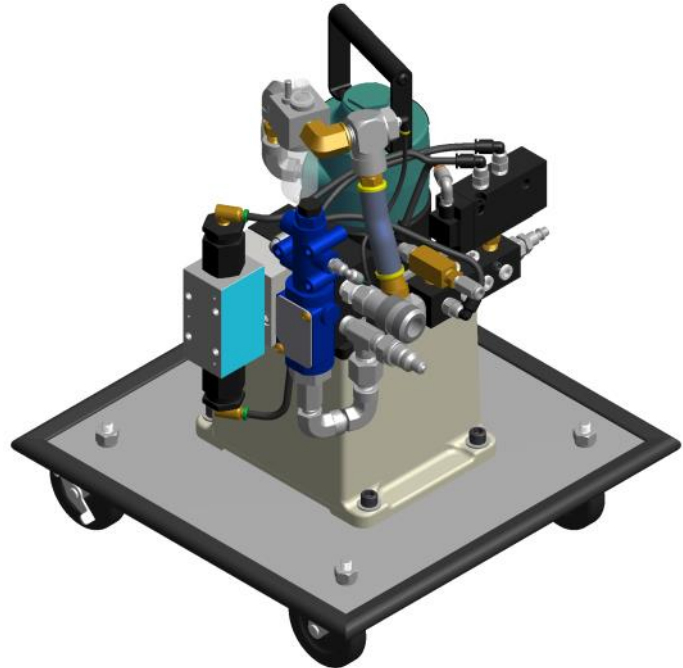

The GB912 Hydraulic Powerunit is a portable power source designed to operate a wide range of hydraulic installation tools. The unit air powered, air actuated and delivers up to 10,000 psi (689.48 bar) working pressure. The actuator on the installation tool remotely controls the hydraulic oil directional flow. The unit consists of a two position air hydraulic pump, four way control valve and relief valve mounted on the reservoir. The rapid tool piston movement is obtained through a higher (12 cubic inches a minute) output pump. Quick disconnect hydraulic couplings and air control socket are included to attach the equipment hydraulic hoses and air control tube.

The GB912 Hydraulic Powerunit is available separately or in kits including hydraulic quick-disconnect couplers, air connectors, air lines and hydraulic hoses in various lengths.

GB912-12 includes the GB912 Powerunit and 12 ft. (3.7m) Hose Kit-Air, part #910701.

GB912-26 includes the GB912 Powerunit and 26 ft. (7.9m) Hose Kit-Air, part #910705.

GB912-38 includes the GB912 Powerunit and 38 ft. (11.6m) Hose Kit-Air, part #910709.

GB912-52 includes the GB912 Powerunit and 52 ft. (15.8m) Hose Kit-Air, part #910714

Images may not reflect actual tools

STANDARD & OFFSET COLLAR FEEDERS

Approved for use on Gage Bilt CE installation tools and/or other manufacturer's CE approved tools of similar design.
(Sold Separately)



**Installation of
5/32"- 3/8" LGP® collars**
Contact Gage Bilt for more information
(Sold Separately)



Gage Bilt Installation tool,
Standard and Offset Collar Feeders
(Sold Separately)

- SAFER COLLAR INSTALLATION
- INCREASE PRODUCTIVITY
- ELIMINATE FOD
- REDUCE FASTENER COSTS
- QUICK-CHANGE CARTRIDGE

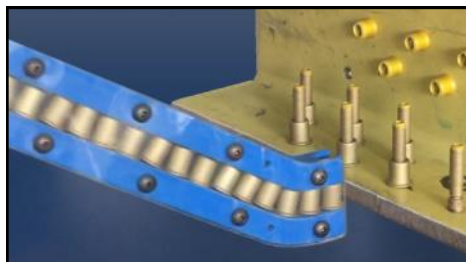
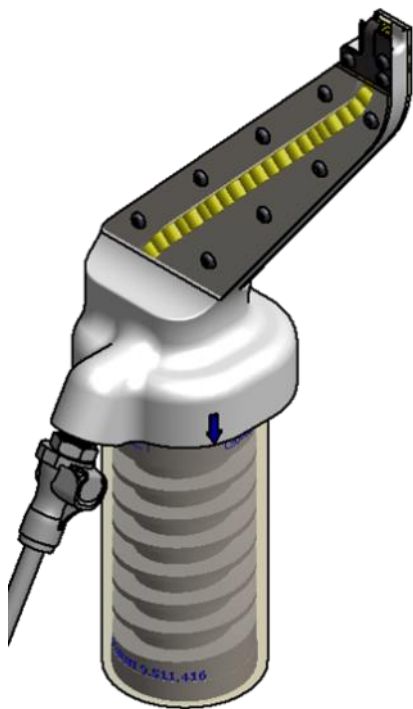

**Installation of
5/32"- 3/8" LGP® collars**
Contact Gage Bilt for more information
(Sold Separately)

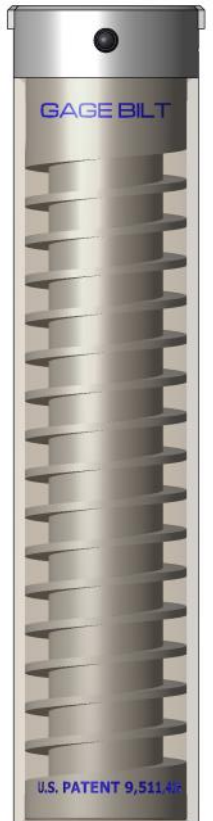

**Collar Feeder Cartridges
Available in
4" and 8" Lengths**
Contact Gage Bilt for
more information
(Sold Separately)



Images may not reflect actual tools

STRAIGHT FEED N SWAGE



Approved for use on Gage Bilt CE installation tools and/or other manufacturer's CE approved tools of similar design.
(Sold Separately)

SWAGING: EASY AS...

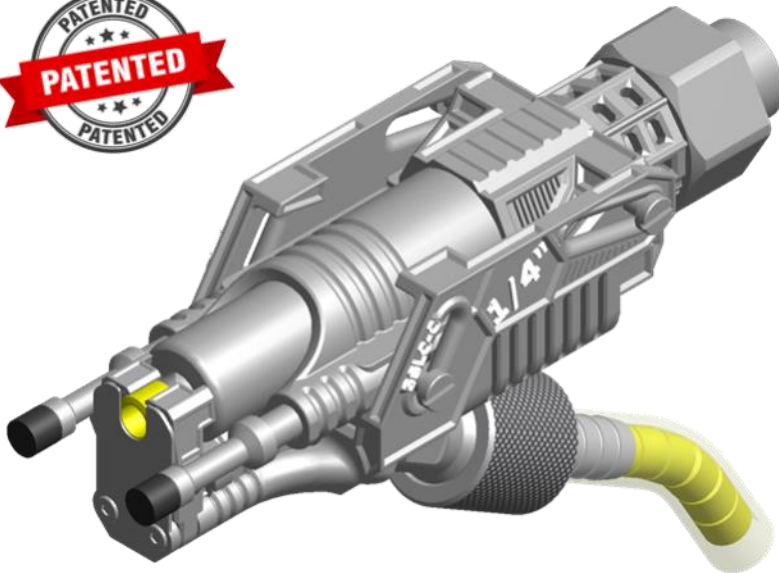

STRAIGHT FEED N SWAGE SEMI-AUTOMATIC INSTALLATION TOOL

FOR USE WITH THE GB731 HYDRAULIC INSTALLATION
TOOL OR THE GB745 HYDRAULIC INSTALLATION TOOL
WITH ADAPTER (745751)

FOR 5/32" - 3/8" LGP® 3SLC-C Collars
Contact Gage Bilt for more information
(Sold Separately)

- SAFER COLLAR INSTALLATION
- INCREASE PRODUCTIVITY
- ELIMINATE FOD
- REDUCE FASTENER COSTS
- EASY FEED TUBE INSTALLATION

1

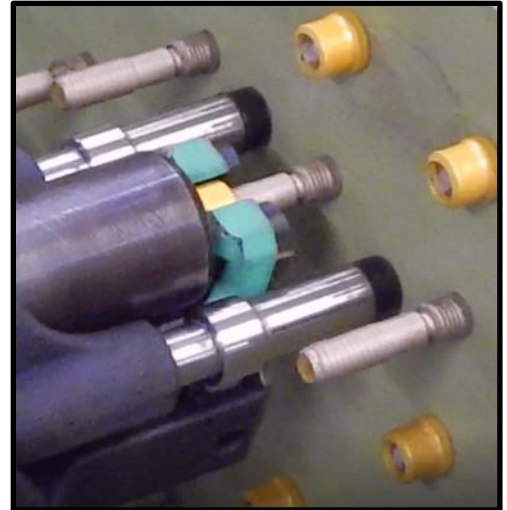

Operator presents nose to pintail and
feeder dispenses collar onto pin.

2

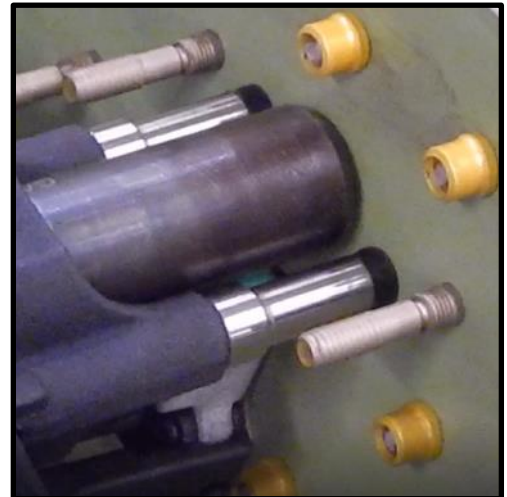

Feeder pivots, exposing nose for
installation, while picking up next collar.

3



Feeder automatically returns to original
position for next lockbolt installation.

Images may not reflect actual tool

COLLAR FEEDER BOWLS

(Sold Separately)

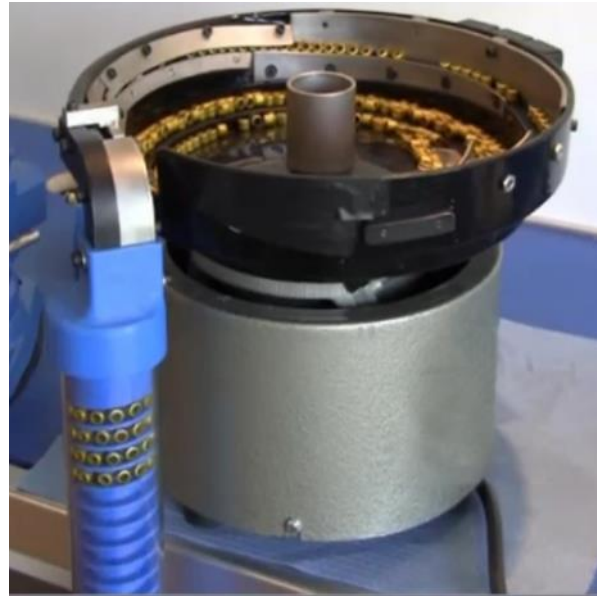

**Collar Feeder Bowl
Feeds collars in Cartridge**
Contact Gage Bilt for more information.
(Sold Separately)

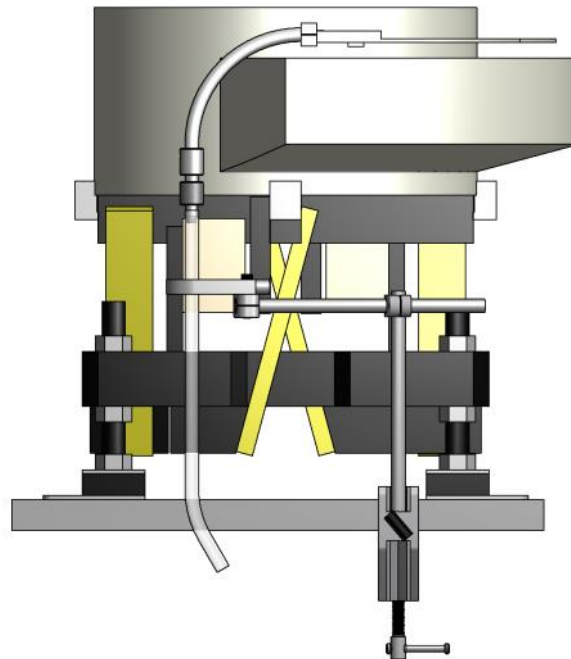

**Collar Feeder Bowl
For Straight Feed N Swage
Feeds collars into feeder tube**
Contact Gage Bilt for more information.
(Sold Separately)

Images may not reflect actual feeder bowl or parts



This page intentionally left blank

Riveter Kits Available

(Sold Separately)



Gage Bilt offers a wide selection of standard and custom kits tailored to your needs.
Contact us for more information.

**CE
Approved**



TEFLON® IS A REGISTERED TRADEMARK OF E.I. DUPONT DE NEMOURS & CO. LUBRIPLATE® IS A REGISTERED TRADEMARK OF FISKE BROTHERS REFINING CO. SLIC-TITE® IS A REGISTERED TRADEMARK OF LA-CO INDUSTRIES INC. LOCTITE® IS A REGISTERED TRADEMARK OF HENKEL CORPORATION. CHERRYMAX® AND CHERRYLOCK® ARE REGISTERED TRADEMARKS OF CHERRY AEROSPACE FASTENERS.