

GB2600

GB2600A

HYDRAULIC
INSTALLATION TOOL

GAGE BILT

RIVET & LOCKBOLT TOOLS

44766 Centre Ct. Clinton Twp. MI 48038 USA

+1 586. 226.1500

+1 586. 226.1505

solutions@gagebilt.com

www.gagebilt.com

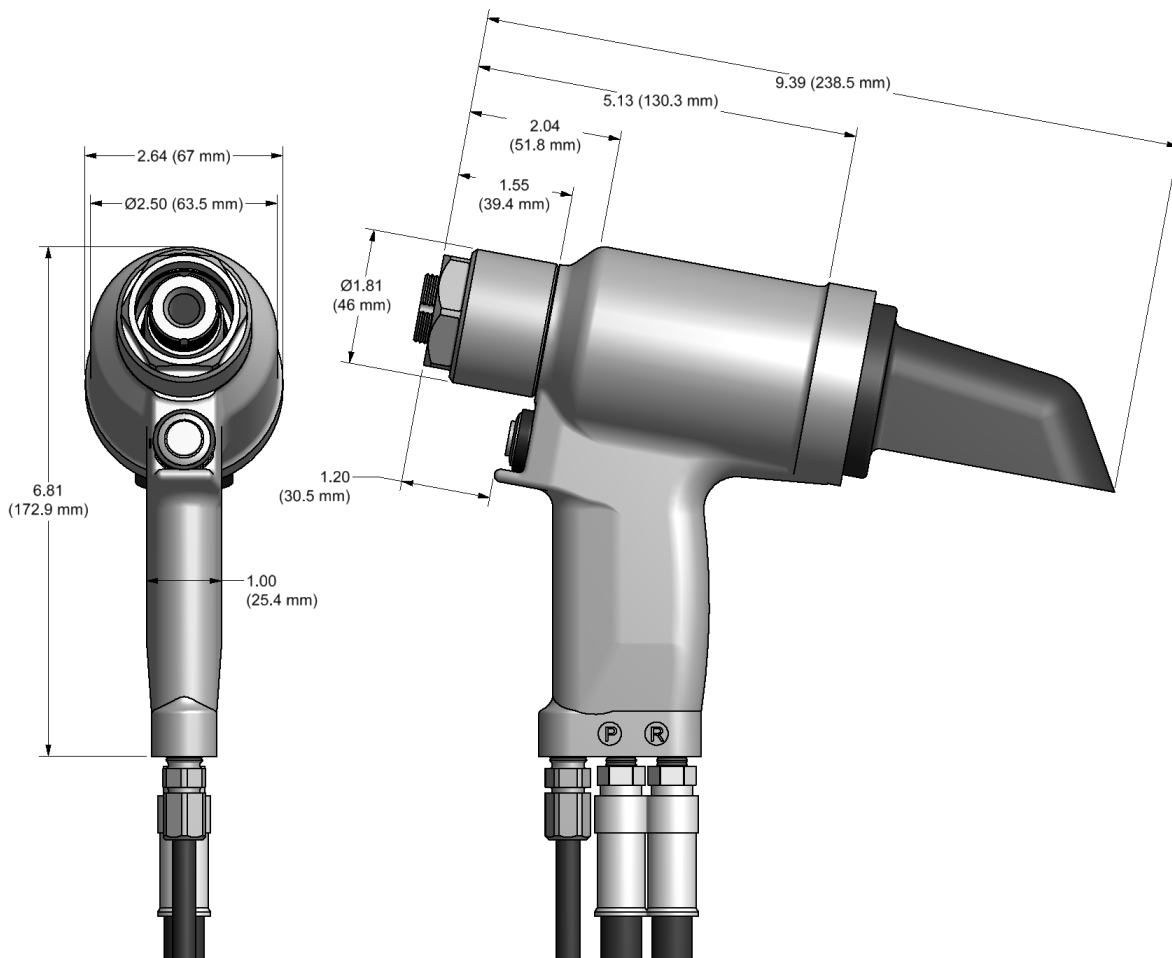

The **GB2600** and the **GB2600A** are hydraulic installation tools designed specifically for the efficient installation of blind fasteners and up to 3/8" (9.5 mm) pintail-style lockbolts. It weighs 7.3 lbs. (3.3 kg) and can be operated in any position. It has a 1.25" (31.8 mm) fastener stroke and a rated pull load of 13,840 lbs. (61.6 kN) @ 5,700 psi. (393 bar).

The **GB2600** electrically actuated installation tool operates on hydraulic pressure developed by the **GB947** Power Unit set at 7,400 psi (510 bar) maximum PULL pressure and 3,200 psi. (220 bar) maximum RETURN pressure. The tool comes equipped with 2 feet (.61 m) of hydraulic hoses and couplings, electric switch and cord.

The **GB2600A** air actuated installation tool operates on hydraulic pressure developed by the **GB910** & **GB912** Power Units set at 7,400 psi (510 bar) maximum PULL pressure and 3,200 psi. (220 bar) maximum RETURN pressure. The tool comes equipped with 2 feet (.61 m) of hydraulic hoses, swivels and couplings, air actuator and tube.

**ALL GAGE BILT HYDRAULIC INSTALLATION TOOLS ARE COMPATIBLE WITH EQUIVALENT POWERUNITS.
NOSE ASSEMBLIES ARE NOT FURNISHED WITH THESE TOOLS AND MUST BE ORDERED SEPARATELY.**





GB2600(A) NOSE ASSEMBLY SELECTION CHART & ACCESSORIES

Approved for use on Gage Bilt CE installation tools and/or other manufacturer's CE approved tools of similar design.
(Sold Separately)

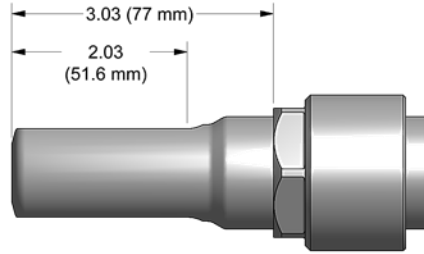

FASTENER	DIA.	STRAIGHT NOSE ASSEMBLY
BOM®	3/8"	BOM12-2600-30 BOM12-2600-60
LGP® LOCKBOLT LGPL2SC-V BACB30VM LGPL18SC-V BACB30XT LGPL4SC-V ABS0548 LGPL2SP-V BACB30VN LGPL4SP-V ASNA2392 LGPL8SC-V BACB30WD LGPL9SC-V BACB30WB LGPL9SP-V BACB30VY BACB31N BACB31P	7/16"	LGP14-2600-30 LGP14-2600-30SC LGP14-2600-65
MAGNA-GRIP®, MULIT-GRIP, MAXLOK® LOCKBOLTS	3/8"	MG12-2600-32

BOM®, LGP® AND MAGNA-GRIP® ARE REGISTERED TRADEMARKS OF HOWMET AEROSPACE. MAXLOK® IS A REGISTERED TRADEMARK OF AVDEL UK LIMITED.

GAGE BILT CERTIFIES THE GB2600 WILL INSTALL THE ABOVE FASTENERS

See gagebilt.com/nose_assemblies.php for nose assembly information (data sheets)

NOTE: THE LAST 2 DIGITS OF THE NOSE ASSEMBLY REPRESENTS THE LENGTH THE NOSE ASSEMBLY EXTENDS FROM THE TOOL. (I.e. -40 = 4.0 inches) 1/23 REV 10/25

WARRANTY

Seller warrants that all goods covered by this catalog will conform to applicable specifications and will replace or repair, EXW our plant, any goods providing defective from faulty workmanship, or material, for 1 year from date of shipment.

Said warranty to remain in effect if, and only if, such goods are used in accordance with all instructions as to maintenance, operation and use, set forth in manuals and instruction sheets furnished by seller.

Sellers obligation under this warranty shall be limited to the repair or rework of the goods supplied or replacement thereof, at Seller's option, and in no case is to exceed the invoice value of said goods. Under no circumstances will the seller be liable for incidental or consequential damages or for damages incurred by the buyer or subsequent user in repairing or replacing defective goods or if the goods covered by this warranty are reworked or subjected to any type of additional processing.

This warranty is void if Seller is not notified in writing of any rejections or defects within 1 year after the receipt of the material by the customer.

THIS WARRANTY IS MADE IN LIEU OF ALL OTHER WARRANTIES EXPRESSED OR IMPLIED, INCLUDING MERCHANTABILITY.