

# NOSE ASSEMBLY DATA SHEET

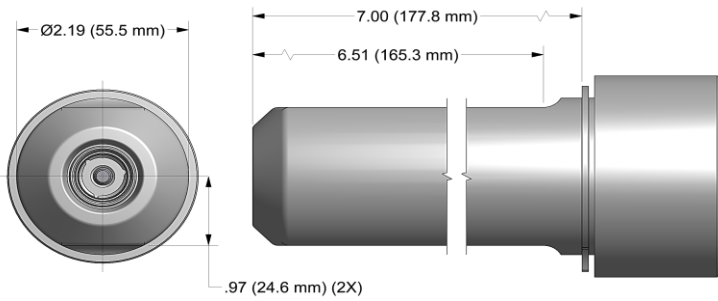

1. Ensure Piston is in full forward position.
2. Disconnect tool control cord.
3. Screw assembled Collet onto Piston until top of collet flat lines up with Adapter face of tool.
4. If Collet Lock (11) is not in Piston groove, continue to turn 1/4 turn clockwise, or less, until lock engages groove.
5. Tighten Set Screw (10) on (new noses).
6. Slide Anvil (1) over assembled Collet. Install Split Ring, Sleeve (furnished with tool) and Retaining Ring (14).

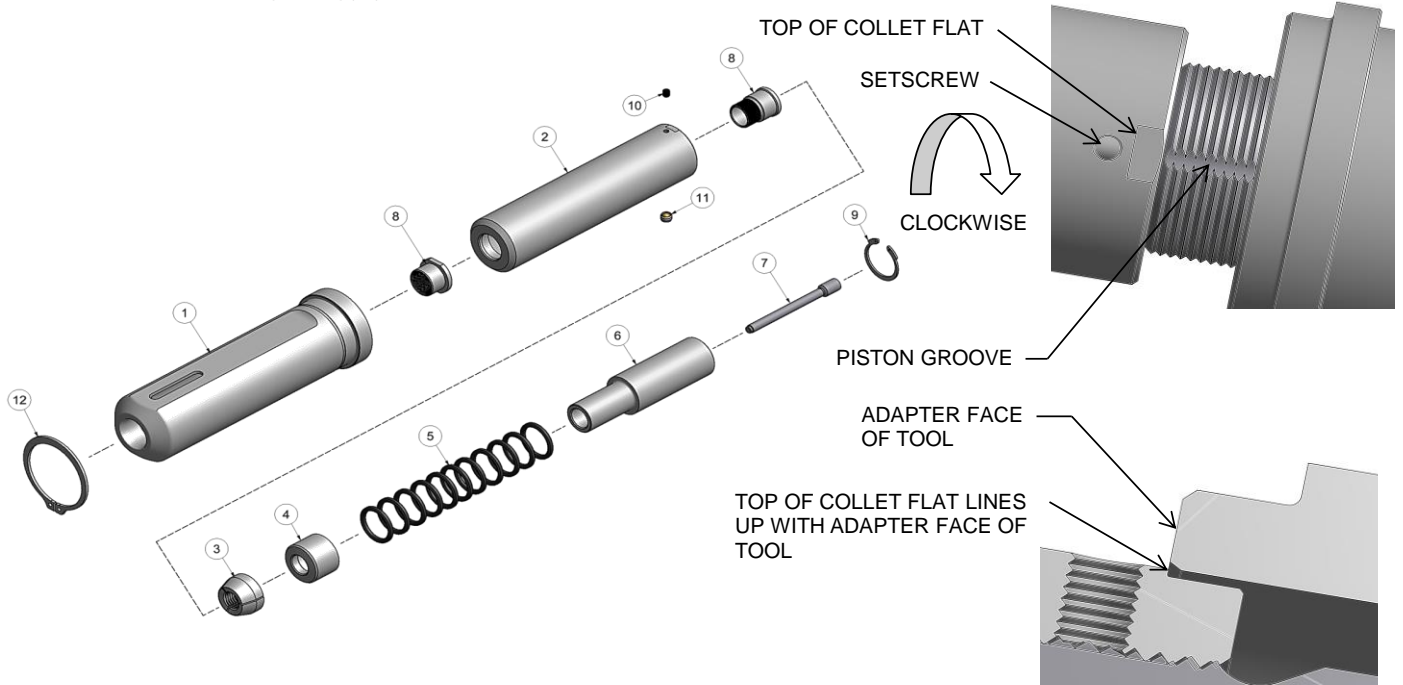

10/08 Rev. 8/16

**GAGE BILT**  
MADE in USA

44766 Centre Court Clinton Twp. MI 48038 USA  
Ph: +1 (586) 226-1500 Fax: +1 (586) 226-1505  
solutions@gagebilt.com / www.gagebilt.com

Type:		Fastener:	Recommended Tool:
Self-Releasing 5/8" Ø		C50L® Lockbolt	GB585
Ref. No.	Qty.	Description	20-585-70
1	1	Anvil	12010
2	1	Collet Assy (Inc. 8, 10 & 11)	22010
3	1	Jaw Set	32001
4	1	Follower	42003
5	11	O'Ring	400846
6	1	Sleeve	62005
7	1	Pintail Ejector	52004
8	1	Release & Ejector Kit	82000
9	1	Retaining Ring	402263
10	1	Socket Set Srew	A-280
11	1	Collet Lock Assy	54502
12	1	Retaining Ring	401027