

NOSE ASSEMBLY DATA SHEET

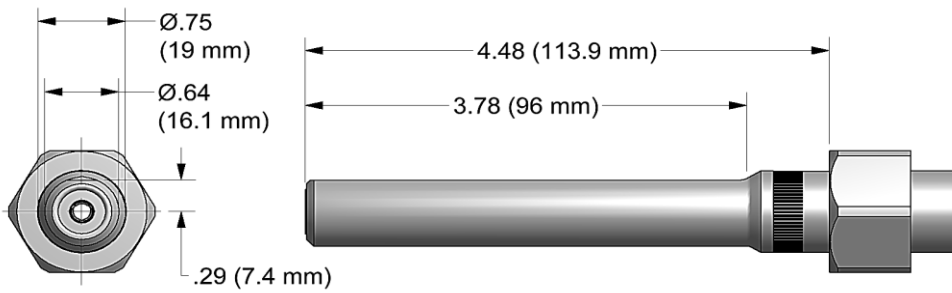

Slots on retaining nut stop, supplied with tool, fit over ears on anvil assembly

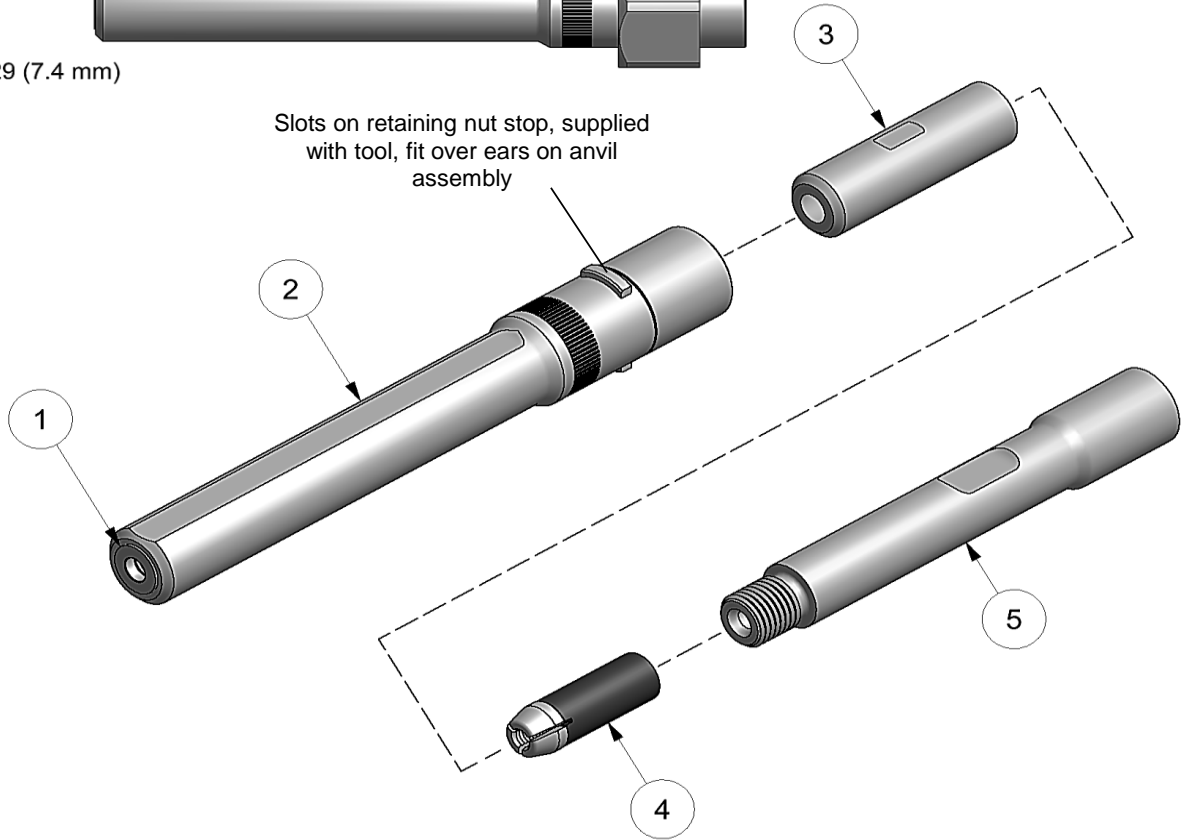

Use Hex-Key in rear of piston for nose assembly attachment.

*Anvil Assembly consists of #1 and 35208 retainer



10/05 Rev. 3/15

GAGE BILT
MADE IN U.S.A.

GAGE BILT Inc.

44766 Centre Court (586) 226-1500
Clinton Twp. MI 48038 (586) 226-1505 Fax
e-mail:solutions@gagebilt.com / www.gagebilt.com

Type:		Fastener:	Recommended Tool:
Non Self-Releasing 1/4" Ø		NAS9301-NAS9312 M7885 BACR15FP/FR BACR15GF/GK	GB752
			Alternate Tools: GB722 & GB2480(A)
Ref. No.	Qty.	Description	08MAX-752B-45
1	1	Anvil-Driving	18009
2	1	Anvil & Holder Assy (Inc. #1)	12202
3	1	Collet	20717
4	1	Super-Grip Jaw Assy	30864-S
5	1	Collet Extension	70551