

NOSE ASSEMBLY DATA SHEET

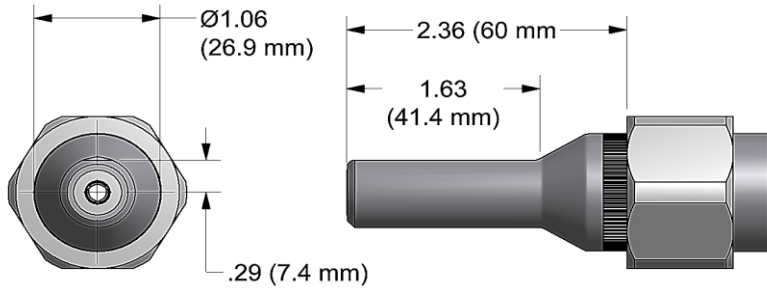

ASSEMBLY:

Note: If nose assy is assembled as it is when purchased new, follow steps 3-5 to attach to tool.

1. Drop super grip jaw assy (4) into collet (3). (Note direction in exploded view).
2. Thread collet (3) to extension-collet (5). Snug tighten assembled parts using 9/16" wrench on collet (3) and on extension - collet (5).
3. Thread assembled collet (3) and extension-collet (5) to piston on tool. Snug tighten assembled parts using 9/16" wrench on extension-collet (5) and hex key in rear of piston on tool.

4. Slide anvil assy (2) over assembled collet (3) and extension-collet (5).

5. Slide Retaining nut and retaining nut stop (see exploded view) on anvil assy (2) and tighten.

DISASSEMBLY:

Reverse assembly instructions.

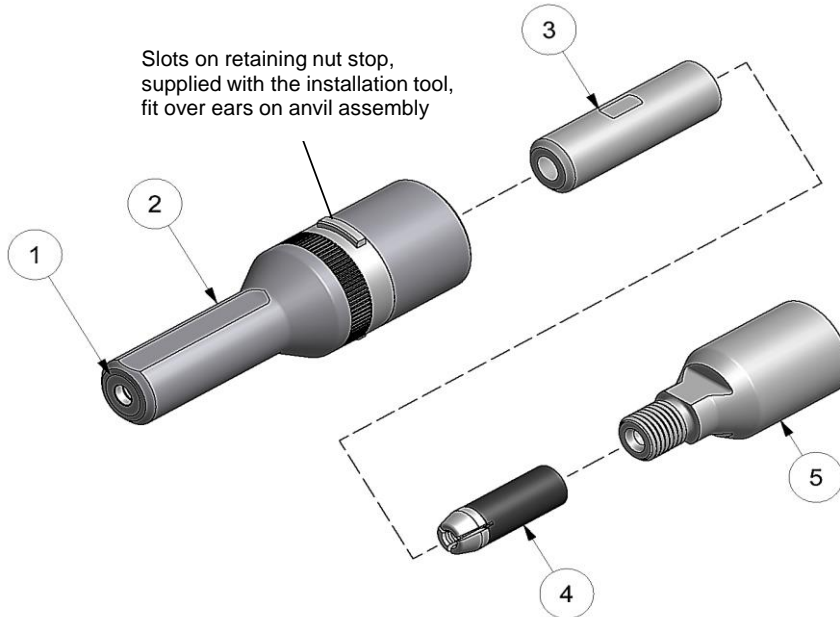

*Anvil Assembly consists of #1 and 35308 retainer

9/04 Rev. 7/16

GAGE BILT
MADE in the USA

GAGE BILT Inc.

44766 Centre Court +1 (586) 226-1500
Clinton Twp. MI 48038 USA +1 (586) 226-1505 Fax
e-mail: solutions@gagebilt.com / www.gagebilt.com

Type:		Fastener:	Recommended Tool:
Non Self-Releasing 1/4" Ø		NAS9301-NAS9312 M7885 BACR15FP/FR BACR15GF/GK	GB745
			Alternate Tools: GB756 & GB2581(A)
Ref. No.	Qty.	Description	08MAX-745B-23
1	1	Anvil-Driving	18009
2	1	Anvil & Holder Assy (Inc. #1)	13342
3	1	Collet	20717
4	1	Super-Grip Jaw Assy	30864-S
5	1	Extension-Collet	70552