

ORIGINAL INSTRUCTIONS

S/N: 1003 AND ABOVE
PLEASE CONTACT GAGE BILT FOR
ALL OTHER SERIAL NUMBERS.

GB745SHV5/LB10

INSTALLATION TOOL



GAGE BILT TOOLS ARE AVAILABLE WORLDWIDE
E-MAIL US FOR A DISTRIBUTOR NEAR YOU.

Registered to
ISO 9001:2015

GAGE BILT
 **MADE in USA**

44766 Centre Court, Clinton Twp., MI. 48038 USA
Ph: +1 (586) 226-1500 Fax: +1 (586) 226-1505
solutions1@gagebilt.com / www.gagebilt.com

TABLE OF CONTENTS



	<u>Page</u>
EU Conformity and Warranty	3
Description and Technical Specifications	4
Description of Functions	5
Warnings.....	6
Principle of Operation	7
How to set-up the GB745SHV5/LB10.....	8
How to use the GB745SHV5/LB10	9
Maintenance and Hydraulic Thread Preparation	10
Filling	11
Bleeding.....	12
Troubleshooting / How to Clean Vacuum Regulator.....	13
Overhaul	14-16
Parts Lists.....	17-19
DEXRON® III Oil Safety Data (SDS)	20
Accessories	21-24

GAGE BILT

DECLARATION OF CONFORMITY

MANUFACTURER: Gage Bilt Inc. 44766 Centre Ct., Clinton Twp., Michigan U.S.A. +1(586-226-1500)

**WE DECLARE THAT THE EQUIPMENT SPECIFIED HEREIN CONFORMS
TO THE FOLLOWING DIRECTIVES AND STANDARDS**

Machinery Directive 2006/42/EC

EN12100-1 & 12100-2:2010

EN ISO 11148-1:2011

The Supply of Machinery (Safety) Regulations 2008

EU REPRESENTATIVE: Edgar Hausmann GmbH Förster-Busch-Str. 10 D-34346 Hann. Münden Germany

EQUIPMENT DESCRIPTION: GB745SHV5/LB10 FASTENER INSTALLATION TOOL

This product specified above conforms to the above directives and standards.

SIGNATURE:



NAME: TIM SIMMONS
PRODUCT MANAGER
CLINTON TWP., MI. U.S.A.
FEB 2023
+1(586) 226-1500



WARRANTY

Seller warrants that all goods covered by this catalog will conform to applicable specifications and will replace or repair, EXW our plant, any goods providing defective from faulty workmanship, or material, for 1 year from date of shipment.

Said warranty to remain in effect if, and only if, such goods are used in accordance with all instructions as to maintenance, operation and use, set forth in manuals and instruction sheets furnished by seller.

Sellers obligation under this warranty shall be limited to the repair or rework of the goods supplied or replacement thereof, at Seller's option, and in no case is to exceed the invoice value of said goods. Under no circumstances will the seller be liable for incidental or consequential damages or for damages incurred by the buyer or subsequent user in repairing or replacing defective goods or if the goods covered by this warranty are reworked or subjected to any type of additional processing.

This warranty is void if Seller is not notified in writing of any rejections or defects within 1 year after the receipt of the material by the customer.

THIS WARRANTY IS MADE IN LIEU OF ALL OTHER WARRANTIES EXPRESSED OR IMPLIED, INCLUDING MERCHANTABILITY.

DESCRIPTION



⚠ WARNING: Any other use is forbidden.

The GB745SHV5/LB10 is a pneumatic-hydraulic installation tool designed specifically for the efficient installation of blind rivets, lockbolts and MAGNA-GRIP® fasteners. This tool's unique "split" system provides the operator with a lightweight ergonomic tool. The head assembly when held in hand weighs 2.25 lbs. (1.02 kg). The entire split handle installation tool weighs 10.50 lbs. (4.76 kg). It has a .620" (15.75 mm) fastener setting stroke.

The GB745SHV5/LB10 installation tool operates on 90 to 100 psi (6.2 - 6.9 bar) of air pressure, with 90 psi. (6.2 bar) providing the maximum efficiency. At 90 psi. (6.2 bar) of air pressure, the GB745SHV5/LB10 does not exceed 80 dB(A) and consumes .30 SCF/cycle (8.50 L/cycle).

The air inlet is provided with 1/4 - 18 female pipe thread for accepting the user's air hose fitting.

The GB745SHV5/LB10 comes with 5 feet (1.5 m) of hose. Pull pressure varies with different length hoses. When ordering specify the shortest length hose possible for your application this will provide optimum pull pressure. For example if your application only requires 6 feet (1.8 m) of hose order installation tool with -6 suffix (GB745SHV6). Please consult our engineering department for specific applications.

NOSE ASSEMBLIES ARE NOT FURNISHED WITH THIS TOOL AND MUST BE ORDERED SEPARATELY. (Contact Gage Bilt for more nose assembly options).

ENVIRONMENTAL USE

⚠ WARNING: Do not operate in an explosive atmosphere.

The GB745SHV5/LB10 can be operated between 0°F - 118°F (-17.8°C / 47.8°C)

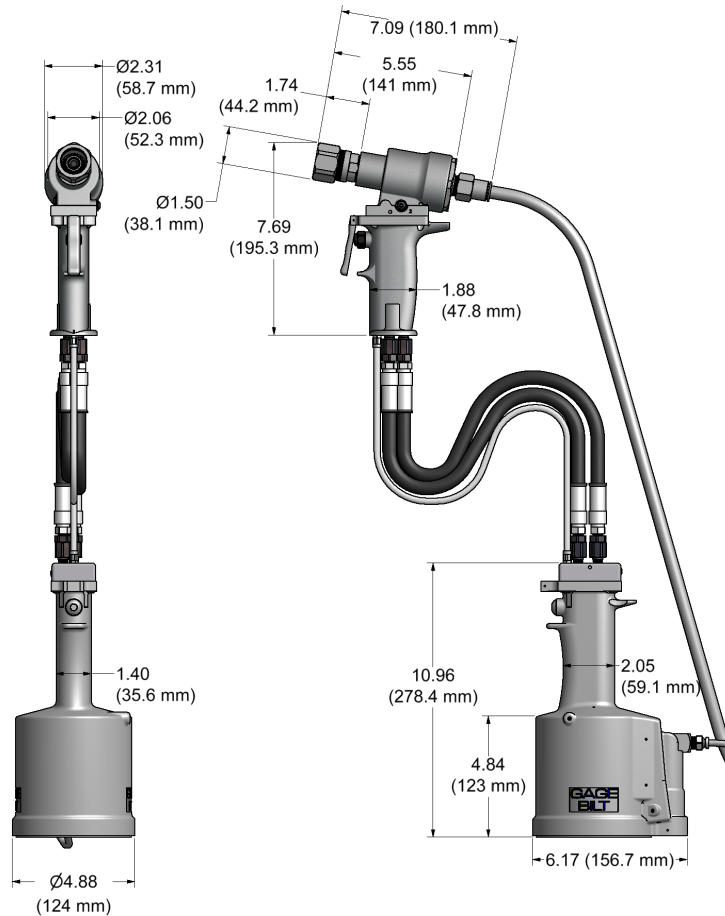

SPECIFICATIONS

Hand Held Weight	- 2.25 lbs. (1.02 kg)
Air pressure req'd	- 90 - 100 p.s.i. (6.2 - 6.9 bar)
Air consumption	- .30 SCF/cycle (8.50 L/cycle)
Hydraulic oil	- Automatic Transmission Oil, Dexron® III, or equivalent.
Setting stroke	- .620" (15.75 mm)
Rated pull load	- 6,300 lbs. (28.02 kN)
Noise level	- Less than 80 dB(A)
Vibration	- Tested – No Hazards Found

DESCRIPTION OF FUNCTIONS

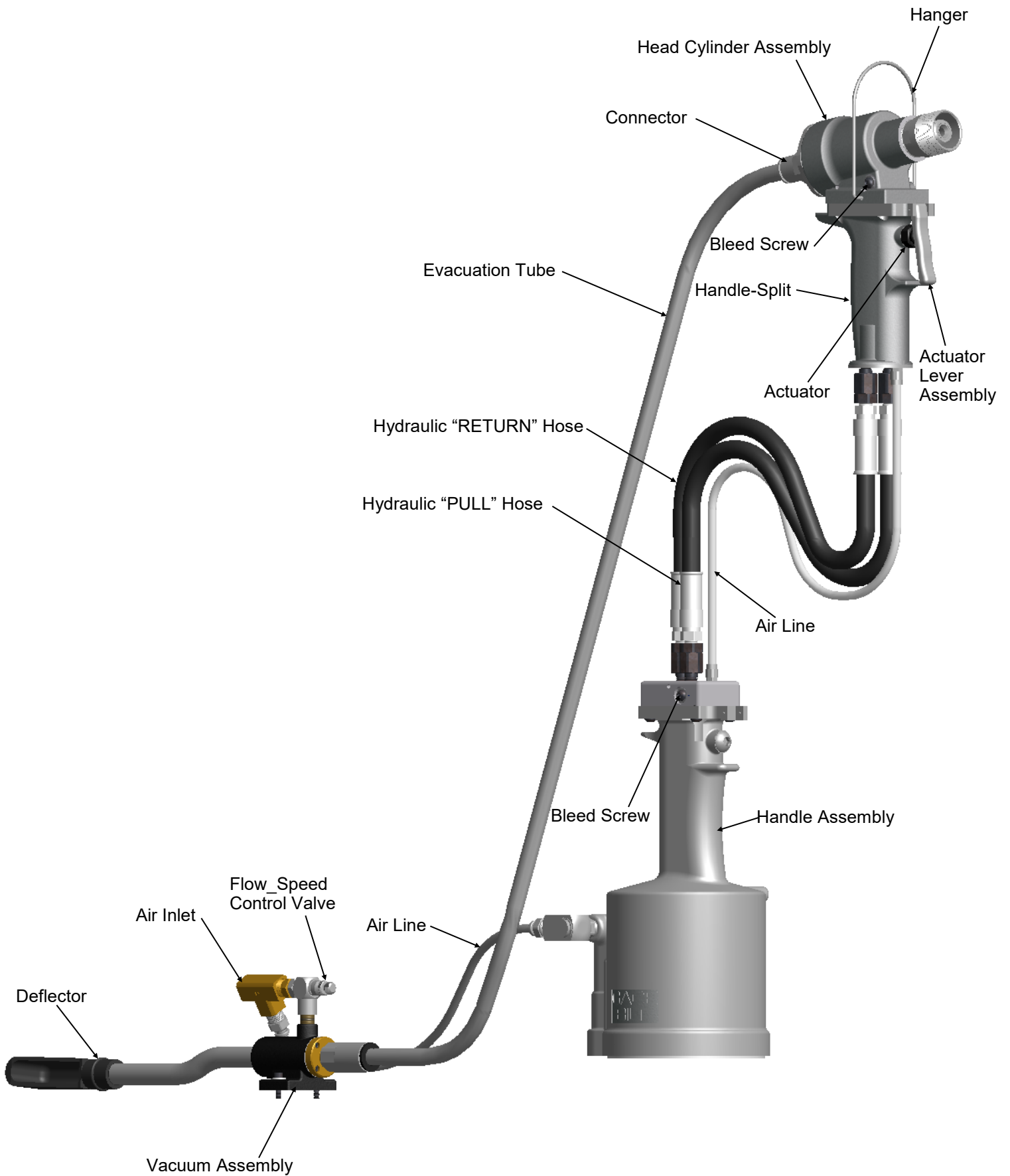

Image may not reflect actual tool



TERMS AND SYMBOLS



- Product complies with requirements



- Product complies with requirements



- Hearing protection and eye protection



- Read manual prior to using equipment



- Wear safety boots



WARNINGS - Must be understood to avoid severe personal injury.



CAUTIONS - show conditions that will damage equipment and/or structure.

Notes - are reminders of required procedures.

GENERAL SAFETY RULES:

1. For multiple hazards, read and understand the safety instructions before installing, operating, repairing, maintaining, changing accessories on, or working near the assembly power tool for non-threaded mechanical fasteners.
2. Only qualified and trained operators shall install, adjust or use the assembly power tool for non threaded mechanical fasteners.
3. Do not modify this assembly power tool for non-threaded mechanical fasteners. Modifications can reduce effectiveness of safety measures and increase the risks to the operator.
4. Do not discard safety instructions; give them to the operator.
5. Do not use assembly power tool for non-threaded mechanical fasteners if it has been damaged.
6. Tools shall be inspected monthly to verify all ratings and markings required are legible. The employer/user shall contact the manufacturer to obtain replacement marking labels when necessary.

ADDITIONAL SAFETY RULES FOR PNEUDRAULIC POWER TOOLS:

1. Air under pressure can cause severe injury.
2. Always shut off air supply, drain hose of air pressure and disconnect tool from air supply when not in use, before changing accessories or when making repairs.
3. Never direct air at yourself or anyone else.
4. Whipping hoses can cause severe injury. Always check for damage or loose hoses and fittings.
5. Cold air shall be directed away from hands.
6. Whenever universal twist couplings (claw couplings) are used, lock pins shall be installed and whip check safety cables shall be used to safeguard against possible hose-to-tool or hose-to-hose connection failure.
7. Do not exceed the maximum air pressure stated on the tool or manual.
8. Never carry an air tool by the hose.

PROJECTILE HAZARDS:

1. Disconnect the tool from the energy source when changing inserted tools/nose assemblies or accessories.
2. Be aware that failure of the workpiece, accessories, or the inserted tool/nose assembly itself can generate high-velocity projectiles.
3. Always wear impact resistant eye protection during operation of the tool.
4. Ensure that the workpiece is securely fixed.
5. Check that the means of protection from ejection of fastener and/or stem is in place and operative (such as the deflector, pintail collection bottle or catcher bag).
6. Forcible ejection of the mandrel from the front of the nose assembly is possible.

OPERATING HAZARDS:

1. Use of tool can expose the operator's hands to hazards, including crushing, impacts, cuts, abrasions and heat. Wear suitable gloves to protect hands.
2. Operators and maintenance personnel shall be physically able to handle the bulk, weight and power of the tool.
3. Hold the tool correctly; be ready to counteract normal or sudden movements and have both hands available.
4. Maintain a balanced body position and secure footing.
5. Release the start-and-stop device in the case of interruption of energy supply.
6. Use only lubricants recommended by the manufacturer.
7. Avoid unsuitable postures as it is likely for these positions not to allow counteracting of normal or unexpected movement of the tool.
8. If the tool is fixed to a suspension device, make sure that fixation is secure.
9. Beware of the risk of crushing or pinching if nose equipment is not fitted.
10. Due to the tool weight, it is recommended safety shoes be worn during operation.
11. It is recommended tool be operated not more than 50 out of every 60 minutes, where prolonged use is expected.

REPETITIVE MOTIONS HAZARDS:

1. When using the tool, the operator can experience discomfort in the hands, arms, shoulders, neck or other parts of the body.
2. While using the tool, the operator should adopt a comfortable posture while maintaining a secure footing and avoiding awkward or off balanced postures. The operator should change posture during extended tasks; this can help avoid discomfort and fatigue.
3. If the operator experiences symptoms such as persistent or recurring discomfort, pain, throbbing, aching, tingling, numbness, burning sensations or stiffness, these warning signs should not be ignored. The operator should tell the employer and consult a qualified health professional.

ACCESSORY HAZARDS:

1. Disconnect tool from energy supply before changing the nose assembly or accessory.
2. Use only sizes and types of accessories approved by the manufacturer. Do not use other types or sizes of accessories.

WORKPLACE HAZARDS:

1. Slips, trips and falls are major causes of workplace injury. Be aware of slippery surfaces caused by use of tool and also of trip hazards caused by the air line or hydraulic hose.
2. Proceed with care in unfamiliar surroundings. There could be hidden hazards, such as electricity or other utility lines.
3. The tool is not intended for use in potentially explosive atmospheres and is not insulated against contact with electrical power.
4. Ensure that there are no electrical cables, gas pipes, etc., which can cause a hazard if damaged by the tool.

NOISE HAZARDS:

1. Exposure to high noise levels can cause permanent, disabling hearing loss and other problems, such as tinnitus (ringing, buzzing, whistling or humming in the ears). Therefore, risk assessment and the implementation of appropriate controls for these hazards are essential.
2. Appropriate controls to reduce the risk may include actions such as damping materials to prevent workpieces from "ringing".
3. Always use hearing protection.
4. Operate and maintain the assembly power tool for non-threaded mechanical fasteners as recommended in the instruction handbook, to prevent an unnecessary increase in the noise level.
5. Select, maintain and replace the consumable/inserted tool as recommended in the instruction handbook, to prevent an unnecessary increase in noise.
6. If the power tool has a silencer, always ensure that it is in place and in good working order when the power tool is being operated.

VIBRATION HAZARDS:

1. Exposure to vibration can cause disabling damage to the nerves and blood supply of the hands and arms.
2. Wear warm clothing when working in cold conditions and keep your hands warm and dry.
3. If you experience numbness, tingling, pain or whitening of the skin in your fingers or hands, stop using the assembly power tool for non-threaded mechanical fasteners, tell your employer and consult a physician.
4. Support the weight of the tool in a stand, tensioner or balancer, because a lighter grip can then be used to support the tool.

PRINCIPLE OF OPERATION





When the actuator lever assembly is depressed, the pressurized air inside of the tool is released allowing spring pressure to move the valve spool assembly causing the air to be redirected. The air is directed to the top of the air piston assembly, moving it in a downward direction. The air below the air piston assembly is then directed through the valve sleeve and exhausted out of the bottom of the tool. Simultaneously, the piston rod assembly connected to the air piston assembly is also moving down, forcing hydraulic oil up and into the front side of the head cylinder assembly, causing the piston to move to the rear of the head cylinder assembly. The internal components of the attached nose assembly are also moving with the piston to start the fastener installation. When the fastener installation is completed, the actuator lever assembly is released. Air pressure is then built up inside of the handle assembly causing the valve spool assembly to return to its original position and reversing the sequence directing oil pressure to the rear of the head cylinder assembly, causing the piston to move to the forward position.

PULL Cycle

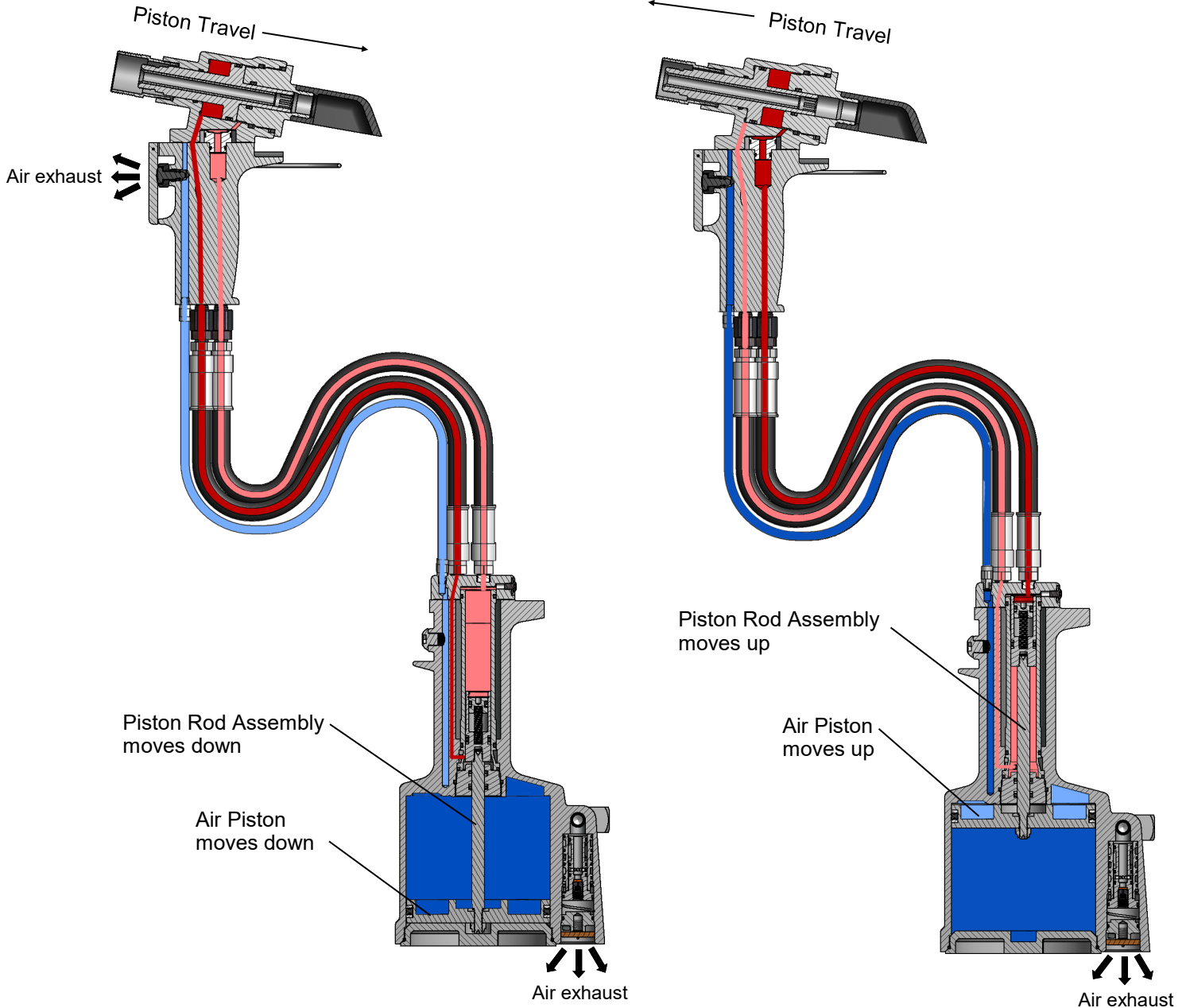
RETURN Cycle



-  Pressurized Oil
-  Unpressurized Oil
-  Pressurized Air
-  Unpressurized Air

Images may not reflect actual tool

HOW TO SET-UP THE GB745SHV5/LB10



- ⚠ WARNING:** Only qualified and trained operators must install, adjust or use the assembly power tool for non-threaded mechanical fasteners.
- ⚠ WARNING:** Operator **MUST** read and understand all warnings and cautions.
- ⚠ WARNING:** It is required that eye protection, hearing protection and safety boots be worn at all times while handling this equipment.
- ⚠ WARNING:** The users or the user's employer must assess specific risks that could be present as a result after each use based on their application.
 - *Ensure there is adequate clearance for tool and operator's hands before proceeding. Keep fingers clear of any moving parts. Keep fingers clear from fasteners and installed materials. Severe personal injury may result.*
 - *Verify the air lines and/or hydraulic hoses are not a trip hazard.*
 - *Ensure that there are no electrical cables, gas pipes, etc., which can cause a hazard if damaged by the tool.*
- ⚠ WARNING:** Do not actuate fastener in the air. Personal injury from fastener ejecting may occur.
- ⚠ WARNING:** Air is exhausted from the bottom of the tool. Direct bottom of the tool (exhausted air) away from operator, other persons working in the vicinity, foreign matter and liquid.
- ⚠ WARNING:** Do not carry from hoses or use as a hammer.
- ⚠ WARNING:** Do not use in explosive atmosphere.
- ⚠ WARNING:** Ensure air hose is securely connected to avoid possible hose whipping.
- ⚠ WARNING:** Always disconnect air supply when tool is not in use to prevent accidental start-up.
- ⚠ WARNING:** Ensure there is adequate clearance for tool and operator hands.
- ⚠ WARNING:** Do not operate this tool without deflector, pintail catcher bag or pintail collection bottle in place.
- ⚠ CAUTION:** Do not use beyond the design intent.

The tool is shipped with a red plastic plug in the air inlet connector. The connector has a 1/4 - 18 female pipe thread to accept user air hose fitting. The tool comes with oil and is ready to use.

1. Remove red plastic shipping plug from Swivel (A-249) (air inlet) and screw in your quick disconnect (air) fitting.
2. Attach connector (745502) to rear of end cap (745330) on rear of head cylinder (745366).
3. Connect tool to air hose with 90 psi. (6.2 bar) using clean, dry air. 3/8" (9.52 mm) minimum diameter air line is recommended. Cycle tool five times by depressing and releasing actuator lever assembly (704343).
4. Disconnect air hose from tool.
5. Select proper nose assembly. Screw collet onto piston and slide anvil over collet and secure with retaining nut (480124). (See proper data sheet for further instructions).
6. Connect air supply.

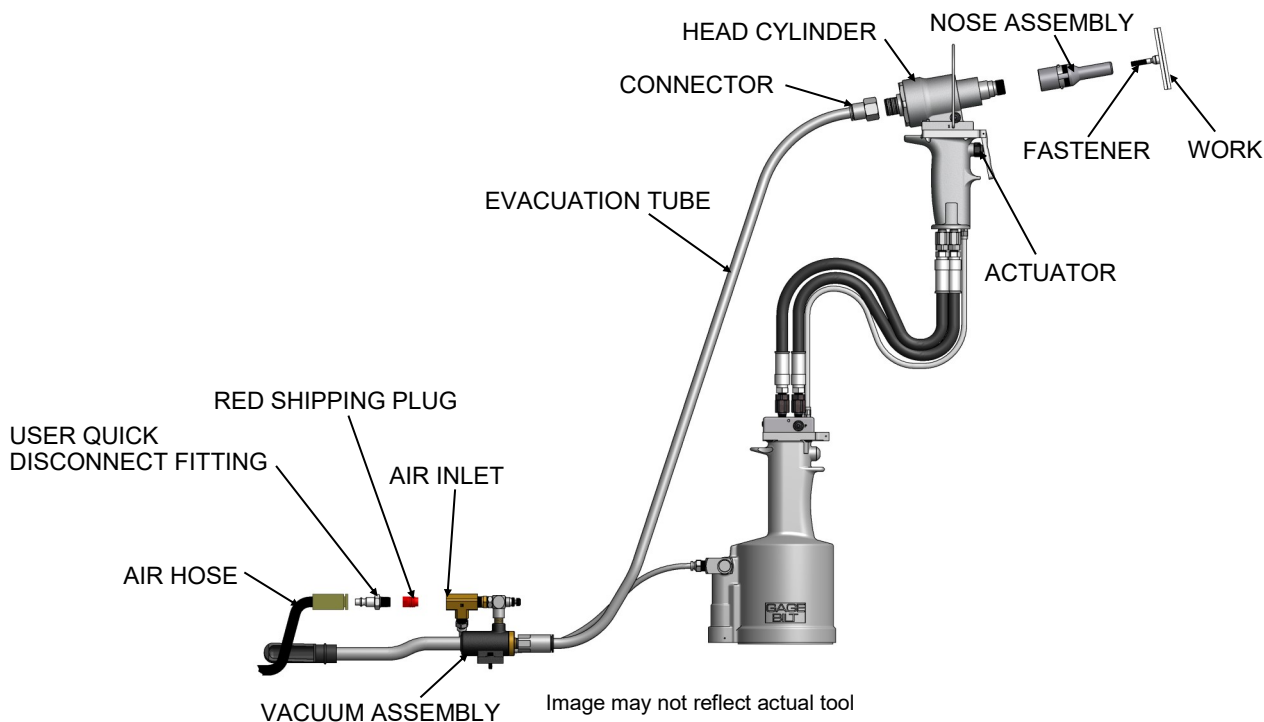

Image may not reflect actual tool

HOW TO USE THE GB745SHV5/LB10



- ⚠ WARNING:** Only qualified and trained operators must install, adjust or use the assembly power tool for non-threaded mechanical fasteners.
- ⚠ WARNING:** Operator **MUST** read and understand all warnings and cautions.
- ⚠ WARNING:** It is required that eye protection, hearing protection and safety boots be worn at all times while handling this equipment.
- ⚠ WARNING:** The users or the user's employer must assess specific risks that could be present as a result after each use based on their application.
 - *Ensure there is adequate clearance for tool and operator's hands before proceeding. Keep fingers clear of any moving parts. Keep fingers clear from fasteners and installed materials. Severe personal injury may result.*
 - *Verify the air lines and/or hydraulic hoses are not a trip hazard.*
 - *Ensure that there are no electrical cables, gas pipes, etc., which can cause a hazard if damaged by the tool.*
- ⚠ WARNING:** Do not actuate fastener in the air. Personal injury from fastener ejecting may occur.
- ⚠ WARNING:** Air is exhausted from the bottom of the tool. Direct bottom of the tool (exhausted air) away from operator, other persons working in the vicinity, foreign matter and liquid.
- ⚠ WARNING:** Do not carry from hoses or use as a hammer.
- ⚠ WARNING:** Do not use in explosive atmosphere.
- ⚠ WARNING:** Ensure air hose is securely connected to avoid possible hose whipping.
- ⚠ WARNING:** Always disconnect air supply when tool is not in use to prevent accidental start-up.
- ⚠ WARNING:** Ensure there is adequate clearance for tool and operator hands.
- ⚠ WARNING:** Do not operate this tool without deflector, pintail catcher bag or pintail collection bottle in place.
- ⚠ CAUTION:** Do not use beyond the design intent.

Lockbolts

1. Insert fastener through the work piece.



2. Slide collar over fastener.

Note: Always hold tool so pulling head is perpendicular to surface of material in which fastener is being installed. Exert firm pressure against fastener during installation.



3. Insert fastener into nose assembly.



4. Press actuator to start cycle.
5. Release actuator as soon as fastener breaks.
6. Repeat steps 1 - 5.

Blind Fasteners

1. Insert fastener.



2. Insert fastener into nose assembly.

Note: Always hold tool so pulling head is perpendicular to surface of material in which fastener is being installed. Exert firm pressure against fastener during installation.

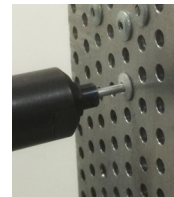

3. Press actuator to start cycle.

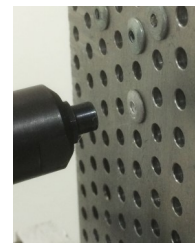

4. Release actuator as soon as fastener breaks.
5. Repeat steps 1 - 4.

Images may not reflect actual tool or rivet

DAILY MAINTENANCE



- ⚠ WARNING:** Tool must be maintained in a safe working condition at all times and examined on a daily basis for damage or wear. Any repair must be done by qualified personnel trained on Gage Bilt procedures.
- ⚠ WARNING:** Excessive contact with hydraulic oil and lubricants must be avoided.
- ⚠ WARNING:** Maintenance personnel **MUST** read and understand all warnings and cautions.
- ⚠ WARNING:** Disconnect tool from its power source before performing maintenance, cleaning or when replacing worn or damaged components. Severe personal injury may occur if power source is not disconnected.
- ⚠ WARNING:** Read material Safety Data Sheet documents for all applicable materials.

Note:

- Dispose of hydraulic oil in accordance with manufacture safety datasheet.
- All tool materials are recyclable except rubber o'rings, seals and wipers.

The performance of any tool depends upon good maintenance practices. Following these minimal requirements daily will extend the life of your tool.

- * Only use a clean dry air supply set at 90 - 100 p.s.i. (6.2 - 6.9 bar) Max. equipped with a filter-regulator to prevent wear.
- * Check tool and nose assembly for damage. (Replace/Repair if necessary). See Overhaul pgs.14 - 16 for tool repair.
- * Inspect hoses and couplings for wear, damage and leaks. (Replace/Repair if necessary). (See hydraulic thread preparation below).
- * Verify that hydraulic hose fittings and couplings, air and electrical connections are secure. Tighten, Replace or Repair if necessary.
- * Cycle the tool several times to assure there are no leaks during use.
- * Keep hydraulic system free of dirt.
- * Proper care by operators is necessary in maintaining full productivity and reducing downtime.
- * Keep nose assemblies, especially jaws, clean and free of chips and debris. Lube jaws and collet surfaces that jaws ride on with light machine oil on a daily basis.
- * All Screwed End Caps, Base Covers, Air Fittings, Air Actuators, Screws and Nose Assemblies are to be examined at the end of each working shift to check that they are secure.
- * For a complete overhaul, service tool kit (GB745SHTK) is recommended. See overhaul pgs. 14 - 16.

WEEKLY MAINTENANCE

- Keep the hydraulic system full (only use Dexron® III or equivalent) and free of air by using the air bleeder assembly (704153) on a weekly basis or as needed. (See Filling and Bleeding procedures pgs. 11 - 12).

SEE TROUBLESHOOTING (PG. 13) AND OVERHAUL (PGS. 14 - 16) FOR FURTHER GUIDANCE.

HYDRAULIC THREAD PREPARATION

IMPORTANT: Be sure to use thread sealant on all hydraulic fittings, Loctite® 545 or equivalent or a non-hardening Teflon® thread compound such as Slic-tite®. Tighten until fitting feels snug and then continue to tighten 1/2 to 1 full turn. **CAUTION:** Over tightening can easily distort the threads. **DO NOT USE TEFLON® TAPE.** **CAUTION:** Teflon® tape is an excellent thread sealer, however, if it is not properly applied, pieces of Teflon® may enter the hydraulic system and cause a malfunction or damage.

CLEANING AND LUBRICATING PROCEDURE

Daily cleaning and lubrication of nose assembly will greatly reduce downtime and increase life of components. Using sewing machine oil, or an equivalent cleaner/lubricant, follow instructions below.

CLEANING

Clean nose assembly daily or as often as needed.

1. Dip into mineral spirits or similar solvent to clean jaws and wash away metal chips and debris. **DO NOT** allow jaws to come in contact with other solvents. **DO NOT** let jaws soak. Dry jaws immediately.
2. Disassemble nose assembly and use a sharp "pick" to remove embedded particles from grooves of jaws.

LUBRICATING

Lubricate nose assembly after each cleaning and as often as needed.

1. Disconnect tool vacuum line (if equipped).
2. Point nose assembly into oil as shown.
3. Cycle tool 8 - 10 times and wipe dry.

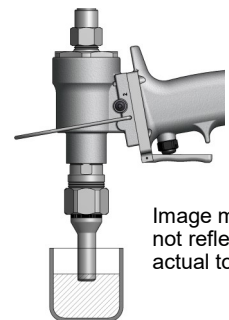

Image may not reflect actual tool

TORQUE SPECIFICATIONS

- Socket Head Cap Screws (400061) = 40 inch lbs. (4.52 Nm).
- Button Head Cap Screws (A-928) = 40 inch lbs. (4.52 Nm).
- Packing Plug (744118) = 45 foot lbs. (61 Nm).
- Flexlock Nut (400559) = 40 inch lbs. (4.52 Nm).
- End Cap (745330) = 45 foot lbs. (61 Nm).
- Button Head Cap Screw (402482) = 35 - 40 inch lbs. (3.95 - 4.52 Nm). (**DO NOT OVER TIGHTEN**).

FILLING PROCEDURE



- ⚠ WARNING:** Do not cycle tool without air bleeder assembly (704153), or the screw and stat-o-seal, installed in tool head. Severe personal injury could result.
- ⚠ WARNING:** Use CAUTION when removing screws, air bleeder assembly (704153) and fill bottle (745263). Hydraulic oil may be under pressure.
- ⚠ CAUTION:** Before filling handle assembly (744129), air piston assembly (744121) must be all the way down.
- ⚠ CAUTION:** When forcing piston rod assembly (745344) downward, with head cylinder (745366) removed, hydraulic oil will eject forcibly from handle assembly (744129).
- ⚠ CAUTION:** When bleeding tool, ensure tubing is free from kinks or other obstructions.

Note:

- Fill Bottle (745263) (sold separately) is required.

* FILLING & BLEEDING VIDEO AVAILABLE AT: http://www.gagebilt.com/rivet_tools_videos.php

IMPORTANT: Be sure to use thread sealant on all hydraulic fittings, Loctite® 545 or equivalent or a non-hardening Teflon® thread compound such as Slic-tite®. Tighten until fitting feels snug and then continue to tighten 1/2 to 1 full turn. **CAUTION:** Over tightening can easily distort the threads. **DO NOT USE TEFLON® TAPE.** **CAUTION:** Teflon® tape is an excellent thread sealer, however, if it is not properly applied, pieces of Teflon® may enter the hydraulic system and cause a malfunction or damage.

1. Put the piston rod wrench assembly (704149) into the top of handle assembly (744129), pushing down firmly until piston rod assembly (745344) is completely in the down position.
2. Fill oil passage and power cylinder (745331) with Automatic Transmission Oil Dexron® III. When looking at the top of the handle assembly (744129) the oil passage is the hole that has a counter bore for o' ring (S832). Do not overfill causing oil to go in air passage hole.
3. Install o'ring (S832), gasket (745124), button head cap screws (A-928) and manifold-handle (745303) to handle assembly (744129), keeping hydraulic hoses (A-1668) towards plug (704313).
4. Remove head cylinder (745366) from handle-split (700326). Slowly push piston (745310) completely to the rear (Dim "B"). Install gasket (745124), o'ring (S832) and socket head cap screws (400061) on handle-split (700326). Assemble head cylinder (745366) to handle-split (700326).
5. Coil tool up on bench and lay handle assembly (744129) down on side so that the hole marked "P" on side of manifold-handle (745303) is to the top. Rest head cylinder (745366) over a small bucket or can. Completely fill up fill bottle (745263).
6. Connect fill bottle to manifold-handle (745303) side hole marked "P". Remove button head cap screw (402482) and stat-o-seal (S572) from head cylinder (745366) hole marked #1.
7. In one continuous squeeze force oil into manifold-handle (745303) until oil starts to flow from bleeder hole on head cylinder (745366) marked #1. While still squeezing the fill bottle, use other hand to replace button head cap screw (402482) and stat-o-seal (S572). This may require two people. Torque to 35 inch lbs. (3.95 Nm). Do not over tighten.
8. Remove fill bottle and replace stat-o-seal (S572) and button head cap screw (402482) in manifold-handle (745303) on side hole marked "P". Torque to 35 inch lbs. (3.95 Nm). Do not over tighten.
9. Connect fill bottle to rear hole on manifold-handle (745303) hole marked "R". Remove button head cap screw (402482) and stat-o-seal (S572) from bleeder hole on head cylinder (745366) marked #2.
10. Repeat step #7 using bleeder hole marked #2.
11. Remove fill bottle and replace button head cap screw (402482) and stat-o-seal (S572) in bleeder hole on head cylinder (745366) and in rear hole on manifold-handle (745303) marked "R". Torque to 35 inch. lbs. (3.95 Nm). Do not over tighten.
12. Once filling procedure is complete, follow bleeding procedure on pg. 12 steps 1 - 9.

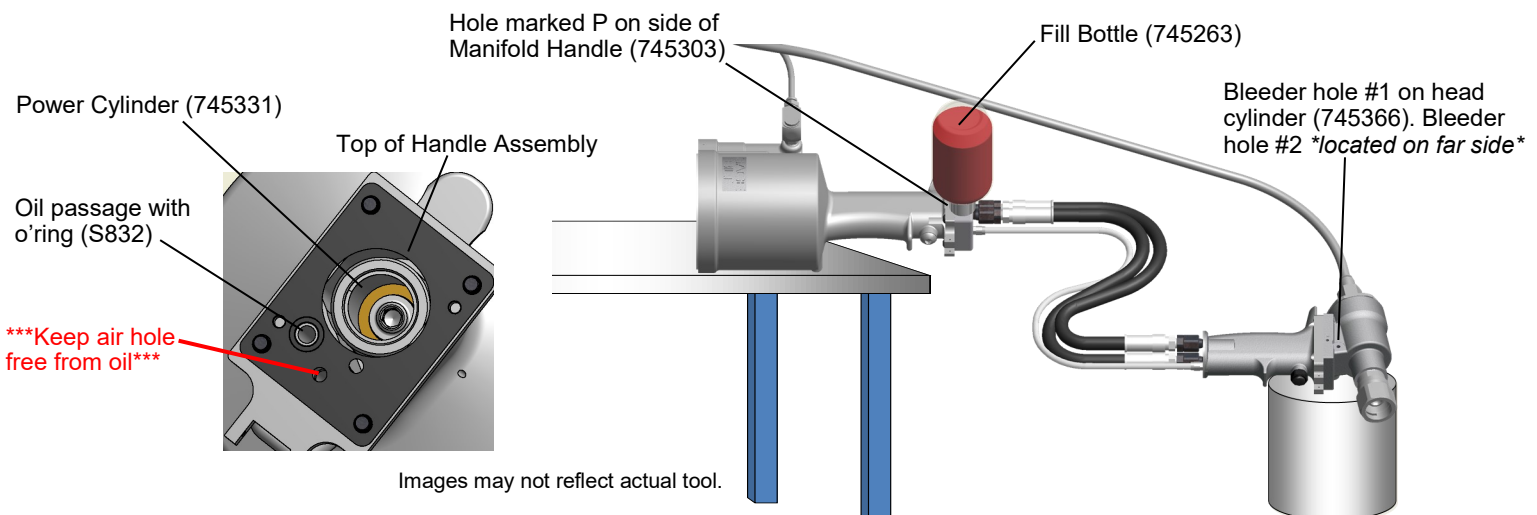

BLEEDING PROCEDURE:



- ⚠ WARNING:** Do not cycle tool without air bleeder assembly (704153), or the screw and stat-o-seal, installed in tool head. Severe personal injury could result.
- ⚠ WARNING:** Use CAUTION when removing screws, air bleeder assembly (704153) and fill bottle (745263). Hydraulic oil may be under pressure.
- ⚠ CAUTION:** Before filling handle assembly (744129), air piston assembly (744121) must be all the way down.
- ⚠ CAUTION:** When forcing piston rod assembly (745344) downward, with head cylinder (745366) removed, hydraulic oil will eject forcibly from handle assembly (744129).
- ⚠ CAUTION:** When bleeding tool, ensure tubing is free from kinks or other obstructions.

Note:

- Air Bleeder Assembly (704153) (sold separately) is required.

* FILLING & BLEEDING VIDEO AVAILABLE AT: http://www.gagebilt.com/rivet_tools_videos.php

1. Stand handle assembly (744129) on floor, stretch hose and head assembly upward and lay flat on a table or bench. When bleeding tool always keep the head assembly higher than the handle assembly.
2. **For "PULL" pressure only:** Attach air bleeder assembly to side hole of manifold-handle (745303) hole marked "P" in an upright position.
3. Connect the tool to air supply and cycle tool ten times holding the actuator assembly-air (704130) down for 2 - 3 seconds between cycles to remove any air from the tool. Leave piston (745310) in **FRONT** position (Dim "A").
4. Disconnect air supply. Remove air bleeder assembly from side hole of manifold-handle (745303) hole marked "P" and replace with button head cap screw (402482) and stat-o-seal (S572). Torque 35 inch lbs. (3.95 Nm). Do not over tighten.
5. Remove button head cap screw (402482) and stat-o-seal (S572) from head cylinder (745366) side hole (marked #1) and attach air bleeder assembly in an upright position.
6. Connect air supply. Cycle tool ten times removing any air bubbles. Leave piston (745310) in **FRONT** position (Dim "A").
7. Disconnect air supply. Remove air bleeder assembly from side hole (marked #1) on head cylinder (745366) and replace button head cap screw (402482) and stat-o-seal (S572). Torque to 35 inch lbs. (3.95 Nm). Do not over tighten.
8. Attach air supply, press and hold actuator lever assembly (704343) leaving piston (745310) in **REAR** position (Dim "B") then disconnect air supply.
9. **For "RETURN" pressure only:** Attach air bleeder assembly to side hole of manifold-handle (745303) hole marked "R" in an upright position.
10. Connect the tool to air supply and cycle tool ten times holding the actuator assembly-air (704130) down for 2 - 3 seconds between cycles to remove any air from the tool. Press and hold actuator lever assembly (704343) leaving piston (745310) in **REAR** position (Dim "B").
11. Disconnect air supply. Remove air bleeder assembly from side hole of manifold-handle (745303) hole marked "R" and replace with button head cap screw (402482) and stat-o-seal (S572). Torque 35 inch lbs. (3.95 Nm). Do not over tighten.
12. Remove button head cap screw (402482) and stat-o-seal (S572) from head cylinder (745366) side hole (marked #2) and attach air bleeder assembly in an upright position.
13. Connect air supply. Cycle tool ten times removing any air bubbles. Leave piston (745310) in **REAR** position (Dim "B").
14. Disconnect air supply. Remove air bleeder assembly from side hole (marked #2) on head cylinder (745366) and replace button head cap screw (402482) and stat-o-seal (S572). Torque to 35 inch lbs. (3.95 Nm). Do not over tighten.
15. Connect air supply. Cycle tool five times and check stroke of .620" (15.75 mm) using instructions a thru c and diagrams below. We recommend using calipers.
 - a. With the actuator lever assembly (704343) released, check dimension (A).
 - b. While holding actuator lever assembly (704343) in, check dimension (B).
 - c. Subtract dimension (A) from dimension (B). If stroke is not consistent within 1/64" (.396 mm) repeat bleeding steps 2 - 15 until stroke met.

For your consideration, Gage Bilt offers a depth gage (Pt.# A-1935) to help simplify and more accurately check your tool stroke. Please contact Gage Bilt for more information.

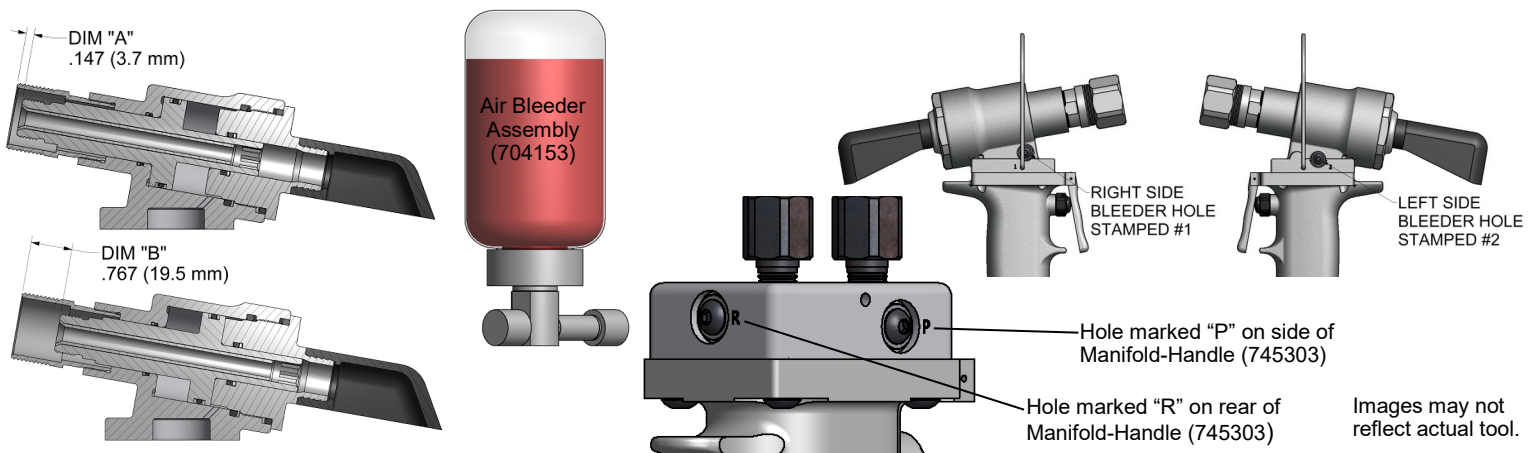

TROUBLESHOOTING



Providing all maintenance conditions have been met, follow this systematic approach to diagnosis.

1. MORE THAN ONE PULL IS REQUIRED TO BREAK FASTENER.

- a) Tool needs to be bled. (See filling and bleeding procedures pgs. 11 - 12).
- b) Spring has fatigued, replace.
- c) Jaws are stripped or packed with chips. Clean or replace.
- d) Incorrect nose tip.

2. SLOW OR PARTIAL OPERATION WHEN THE ACTUATOR LEVER ASSEMBLY (704343) IS DEPRESSED.

- a) O'ring (403815) and back-up ring (401119) on the piston (745310) could be worn or damaged. Replace.
- b) O'ring (A-201) and back-up ring (S908) on the piston rod assembly (745344) could be worn or damaged. Replace.
- c) Muffler (744143) or filter inside valve spool assembly (743142) may be plugged with dirt. Clean thoroughly and back-blow with compressed air.
- d) Hole in metering screw in valve spool assembly (743142) may be blocked or damaged. Hole diameter should be .028" (.71 mm). Clear and size or replace.

3. NO OPERATION WHEN THE ACTUATOR LEVER ASSEMBLY (704343) IS DEPRESSED.

- a) Tool seized due to mechanical failure or damaged parts.

4. OIL LEAKAGE

- a) **DO NOT** OPERATE WITH OIL LEAKING FROM TOOL. HIGH PRESSURE OIL MAY CAUSE SEVERE PERSONAL INJURY.
- b) Any oil leaking externally should be traced to its source. An o'ring or seal that leaks should be replaced.

5. AIR BYPASS FROM VALVE HOUSING.

- a) If the spring (744144) breaks or dislodges, air will flow freely through the muffler (744143). Replace or reset. Valve spring installation tool (744251) is recommended.
- b) Check o'rings on valve sleeve (743144), valve spool assembly (743142), and valve plug (744142). If worn or damaged, replace. Valve sleeve removal tool (744152) is recommended.

6. FASTENER STEM JAMMED IN NOSE ASSEMBLY.

- a) Nose assembly components require service. **DISCONNECT AIR FROM TOOL**, remove the nose from the tool and disassemble. Replace worn or broken parts. Clean the surface the jaws ride on.
- b) Stems lodged side by side in the follower. Disassemble, remove stems, and reassemble.
- c) Incorrect follower.

7. PINTAIL IS NOT BEING VACCUMED THROUGH.

- a) Check vacuum pressure using vacuum gage (703567) (sold separately).
Note: Offset nose assemblies must be check by removing the vacuum line from the nose assembly.
- b) Press gage against the vacuum line or nose assembly to create seal.
Optimum vacuum pressure at nose assembly must be between 15 - 22 inHg. (381 - 558.8 mmHg). If pressure is not met, clean vacuum regulator (A-1676) (see below).
- c) Check bend radius in vacuum line. Minimum of 24" (609.1 mm) bend radius is recommended.

HOW TO CLEAN VACUUM REGULATOR

1. Remove vacuum regulator (703515) from tube and fitting.
2. Remove (4) S.H.C.S. from front of regulator and disassemble.
3. Clean both pieces in clean mineral spirits and blow dry.
4. Reassemble and connect hoses.
5. Check vacuum pressure using vacuum gage (703567) (sold separately).
Press gage against the vacuum line or nose assembly to create seal.
Optimum vacuum pressure at nose assembly must be between 15 - 22 inHg. (381 - 558.8 mmHg).

Note: The vacuum regulator may visually appear clean, but still may be contaminated with a thin film, therefore, the steps above should be performed to assure best performance.

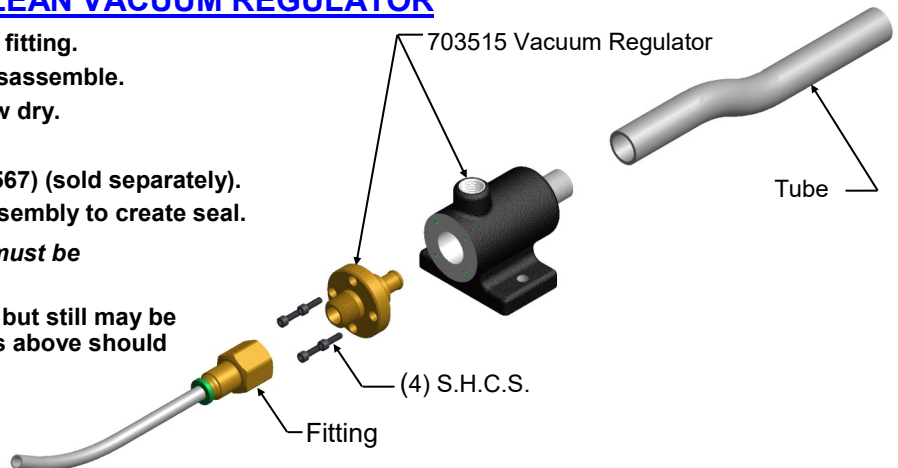

Image may not reflect actual tool.

OVERHAUL



- ⚠ WARNING:** Only qualified and trained personnel shall perform overhaul.
- ⚠ WARNING:** Personnel must read and understand all warnings and cautions.
- ⚠ WARNING:** Tool must be maintained in a safe working condition at all times and examined on a daily basis for damage or wear. Any repair must be done by qualified personnel trained on Gage Bilt procedures.
- ⚠ WARNING:** Disconnect tool from its power source before performing overhaul. Severe personal injury may occur if power source is not disconnected.
- ⚠ WARNING:** Excessive contact with hydraulic oil and lubricants must be avoided (See safety data sheet documents for all applicable materials).
- ⚠ WARNING:** When operating, repairing or overhauling tool, wear approved eye protection. Do not look in front of tool or rear of tool when installing fastener.
- ⚠ WARNING:** Use only Gage Bilt hydraulic hoses and couplings, or equivalent, rated for 10,000 psi. (689.5 bar) working pressure.
- ⚠ WARNING:** Ensure air hose is securely connected to avoid possible hose whipping (Air Actuated Tools only).
- ⚠ WARNING:** Depress actuator assembly-air (704130) and disconnect from air, with the piston in the rear position, before overhaul. Severe personal injury may occur if air hose is not disconnected. **USE CAUTION** when forcing piston rod assembly downward with head cylinder removed. Hydraulic oil will eject forcibly from handle assembly.

Note:

- Dispose of hydraulic oil in accordance with manufacture safety datasheet.
- All tool materials are recyclable except rubber o’rings, seals and wipers.
- It is recommended that service tool kit (GB745SHTK) (see below) be used to facilitate overhaul.
- Use of **SERVICE KIT (745015)**, which contains a complete set of o’rings, back-up rings, screws, washers and gasket, can achieve a complete overhaul.
- Use of **SERVICE KIT (745021)**, that only includes the seals for the hydraulic portion of the tool, can achieve a complete hydraulic overhaul is also available.

Perform overhaul in a clean, well lit area using care not to scratch or nick any smooth surface that comes in contact with an o’ring. Use of Lubriplate® (Gage Bilt part no. 402723) or other lubricant is recommended during reassembly to prevent tearing or distorting of o’rings.

The disassembly and re-assembly procedure can be accomplished by utilizing the following instructions and parts list on pgs. 14 - 18. Use extreme care during disassembly and re-assembly not to mar or nick any smooth surface that comes in contact with seals. Before installing seals, always apply a good lubricant, such as Lubriplate®, to the surfaces.

Clean parts in mineral spirits or other o’ring compatible solvent being sure to clean o’ring grooves. Inspect components for scoring, excessive wear or damage.

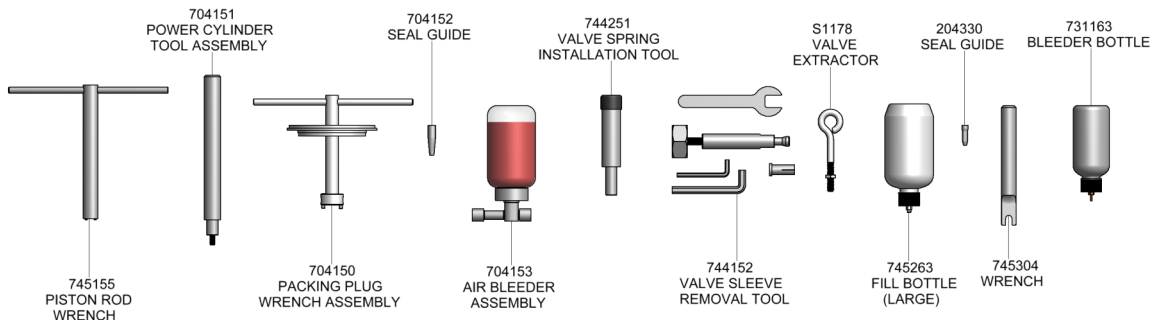

GB745SHTK Service Tool Kit

Part No.	Description
745155	Piston Rod Wrench
704150	Packing Plug Wrench Assembly
704151	Power Cylinder Tool Assembly
704152	Seal Guide
704153	Air Bleeder Assembly
S1178	Valve Extractor
744251	Valve Spring Installation Tool
744152	Valve Sleeve Removal Tool
745263	Fill Bottle (Large)
204330	Seal Guide
745304	Wrench
731163	Bleeder Bottle

TOOL DISPOSAL

1. When tool life is met, drain hydraulic oil from tool and dispose of the hydraulic oil in accordance with the safety datasheet.
2. Disassemble tool and remove all rubber o’rings, seals, wipers and hydraulic hoses. All tool materials are recyclable except rubber o’rings, seals, wipers and hydraulic hoses. Dispose of rubber materials in accordance with the material safety datasheet.



ACTUATOR ASSEMBLY-AIR

- ⚠ WARNING:** Disconnect tool from its power source before actuator removal or installation. Severe personal injury may occur if power source is not disconnected.
- ⚠ CAUTION:** Actuator assembly-air (704130) can break if not careful.
- ⚠ CAUTION:** Do not over tighten actuator assembly-air (704130). Snug tighten only.

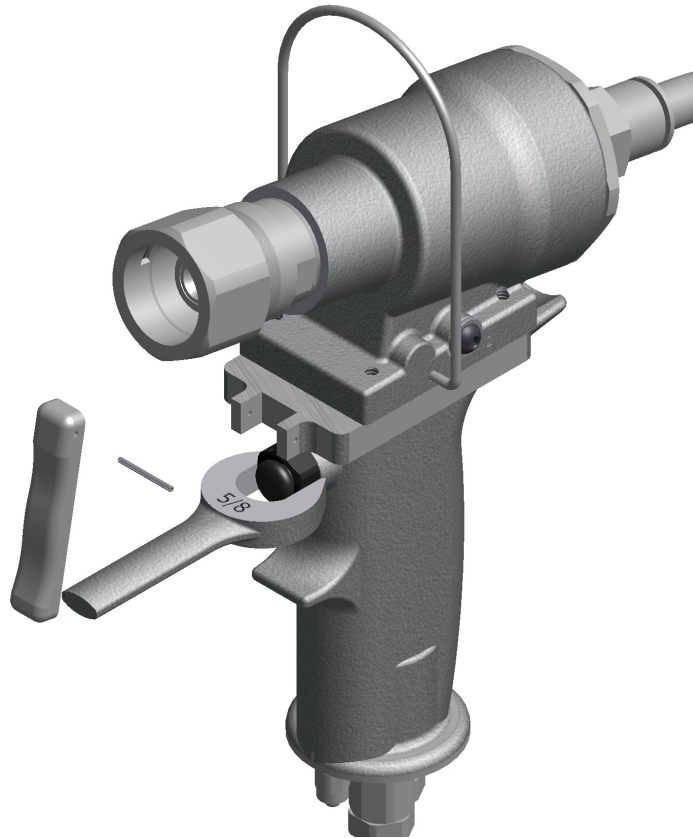

REMOVING ACTUATOR ASSEMBLY-AIR (704130)

1. Remove actuator lever assembly (704343) and pin-slotted (400608).
2. Insert a 5/8" open end wrench / adjustable wrench around actuator assembly-air (704130).
3. Loosen the actuator assembly-air (704130).
4. Remove wrench. Unthread and remove the actuator assembly-air (704130) with fingers from the handle-split (700326).

INSTALLING ACTUATOR ASSEMBLY-AIR (704130)

1. Apply Teflon® tape onto threads of actuator assembly-air (704130) one to two wraps.
2. Thread the actuator assembly-air (704130) all the way into handle-split (700326) with fingers.
3. Insert and turn 5/8" open end wrench / adjustable wrench and snug tight approximately 1/4 - 1/2 turn.
4. Reattach actuator lever assembly (704343) and pin-slotted (400608).



⚠ WARNING: Disconnect tool from its air source before disassembly.

HEAD

1. Remove nose assembly and adapter from tool before attempting disassembly of head cylinder (745366).
2. Remove end cap (745330).
3. Push against threaded end of piston (745310) to slide it out of head cylinder (745366). Be careful not to damage threads or cause burrs on polished piston rod surface.

The re-assembly sequence is the opposite of disassembly. (See Filling and Bleeding procedures pgs. 11 - 12). Apply Loctite® #242 and torque the button head cap screws (A-928) uniformly to 40 inch lbs. (4.52 Nm) to prevent leakage around the gasket (745124).

HANDLE

To inspect air cylinder bore, remove base cover (744124). Any further disassembly will require removal of the head cylinder (745366) first.

For complete disassembly.

1. Remove base cover (744124).
2. Holding tool upright, remove four button-head cap screws (A-928). Lift manifold-handle (745303) from handle assembly (744129) and set aside o-ring (S832) and gasket (745124).
3. Empty all hydraulic oil into an approved container and dispose of in accordance with the safety data sheet.
4. Place piston rod wrench (745155) down into top of power cylinder (745331) and into the hex of piston rod assembly (745344). While holding the piston rod wrench (745155), remove flexlock nut (400559) using a 7/16" socket wrench or an adjustable wrench. Still holding piston rod wrench (745155), remove air piston assembly (744121) using packing plug wrench assembly (704150), by turning counterclockwise.
5. When air piston assembly (744121) is completely free from piston rod assembly (745344), tap or push on the piston rod wrench to eject air piston assembly (744121) from bottom of handle assembly (744129).
6. After removal of air piston assembly (744121), slide piston rod assembly (745344) back up to the end of its travel. Using packing plug wrench assembly (704150) remove packing plug (744118).
7. With packing plug (744118) removed, power cylinder (745331) can be removed by pushing on power cylinder tool assembly (704151) when inserted into top of power cylinder (745331).

To reassemble the handle assembly (744129).

1. Reverse the above procedure, being certain that all o-rings are properly lubricated before installation. Torque packing plug (744118) to 45 foot lbs. (61 Nm).
2. Attach the seal guide (704152) to the piston rod assembly (745344) and tap the piston rod assembly (745344) through the packing plug (744118).
3. Attach air piston assembly (744121) and flexlock nut (400559). Torque flexlock nut to 40 inch lbs. (4.52 Nm).
4. Attach air piston assembly (744121) to piston rod assembly (745344).
5. With the piston rod in the down position, fill oil passage on top of handle assembly (744129) with automatic transmission oil, Dexron® III or equivalent. When looking at top of handle assembly (744129) the oil passage is the hole that has a counterbore for (S832) o-ring.
6. Replace gasket (745124) and o-ring (S832), just prior to replacing head cylinder (745366). Torque all screws to manual specifications. (See Filling and Bleeding procedures pgs. 11 - 12) & (See torque specs. pg. 10).

AIR VALVE

1. Remove pin (744149) and muffler (744143).
2. Insert valve extractor (S1178) into end of valve plug (744142) and pull it out.
3. Using the same procedure, pull out valve spool assembly (743142).
4. It should never be necessary to remove valve sleeve (743144) unless the ports in the valve sleeve (743144) are plugged from contaminated air. If ports are plugged, use needle nose pliers to grasp end of spring (744144), turning clockwise and pulling to dislodge from groove in casting. Valve spring installation tool (744251) will facilitate the proper installation of the spring (744144).
5. Valve sleeve (743144) can be pulled out using valve sleeve removal tool (744152).

PARTS LIST

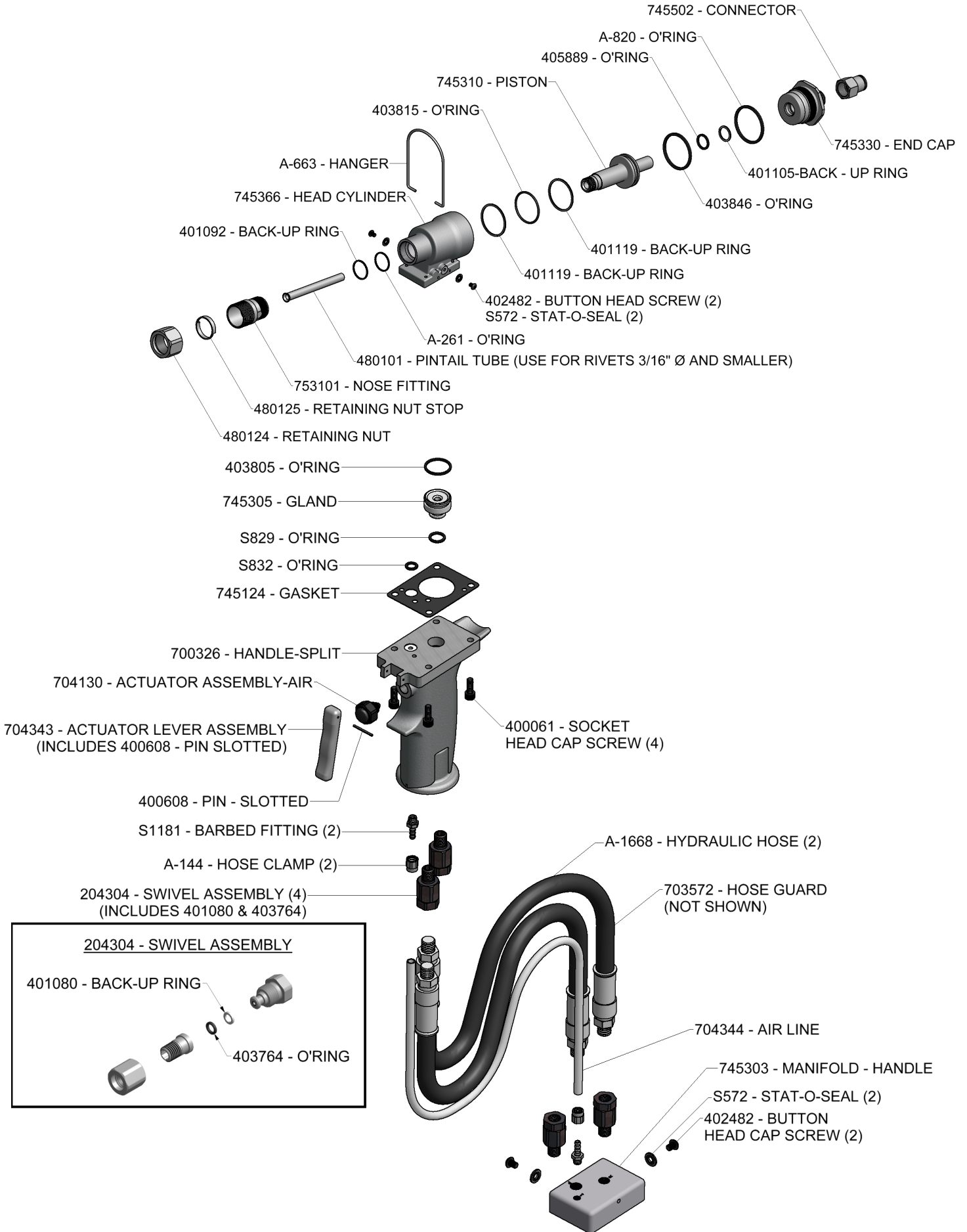

PARTS LIST

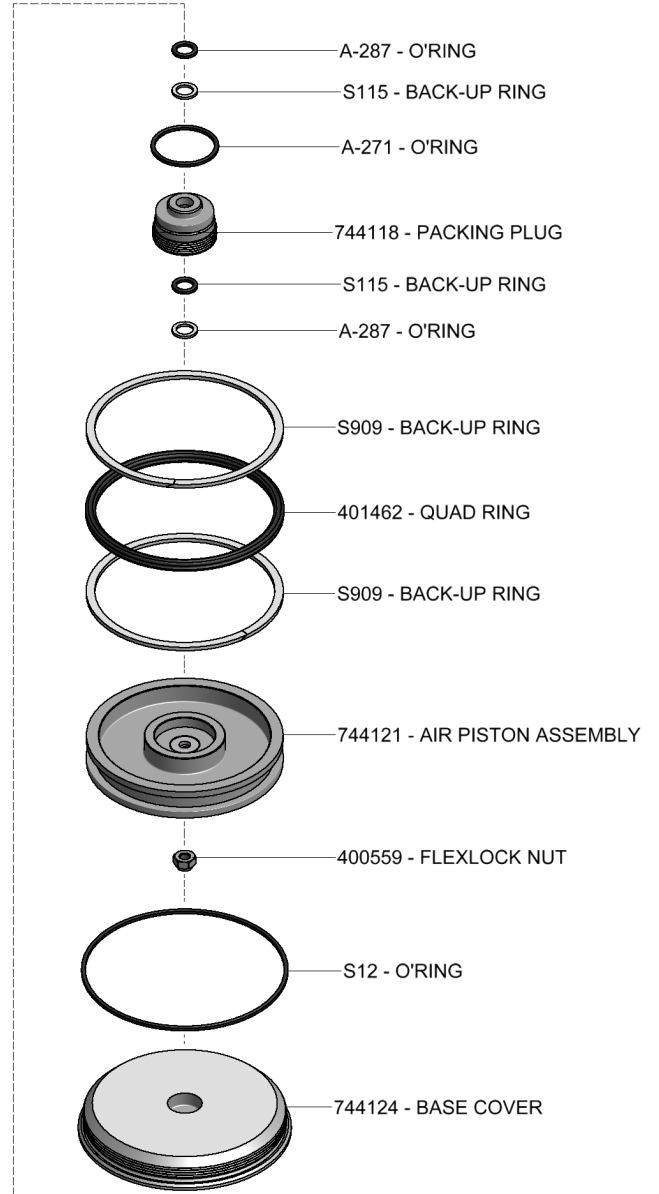
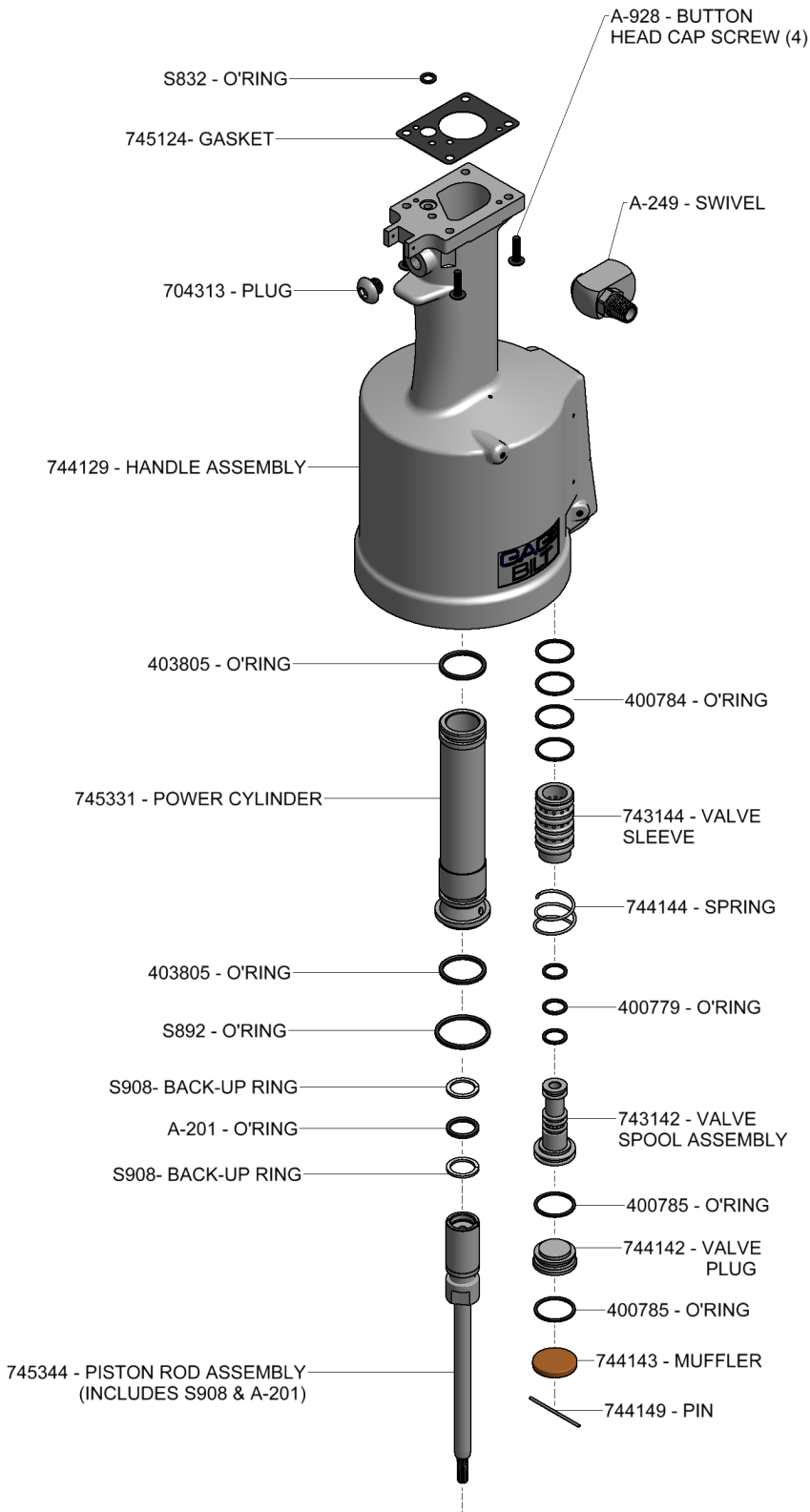

⚠ WARNING:
 This tool incorporates a patented hydraulic relief valve. When overhauling tool, o-ring (A-287), back-up ring (401101), retaining ring (400936) and spring (50806) must be replaced. Failure to do so could result in SEVERE PERSONAL INJURY!

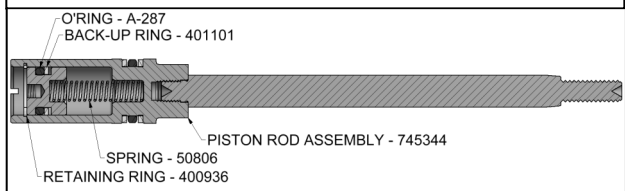

PARTS LIST

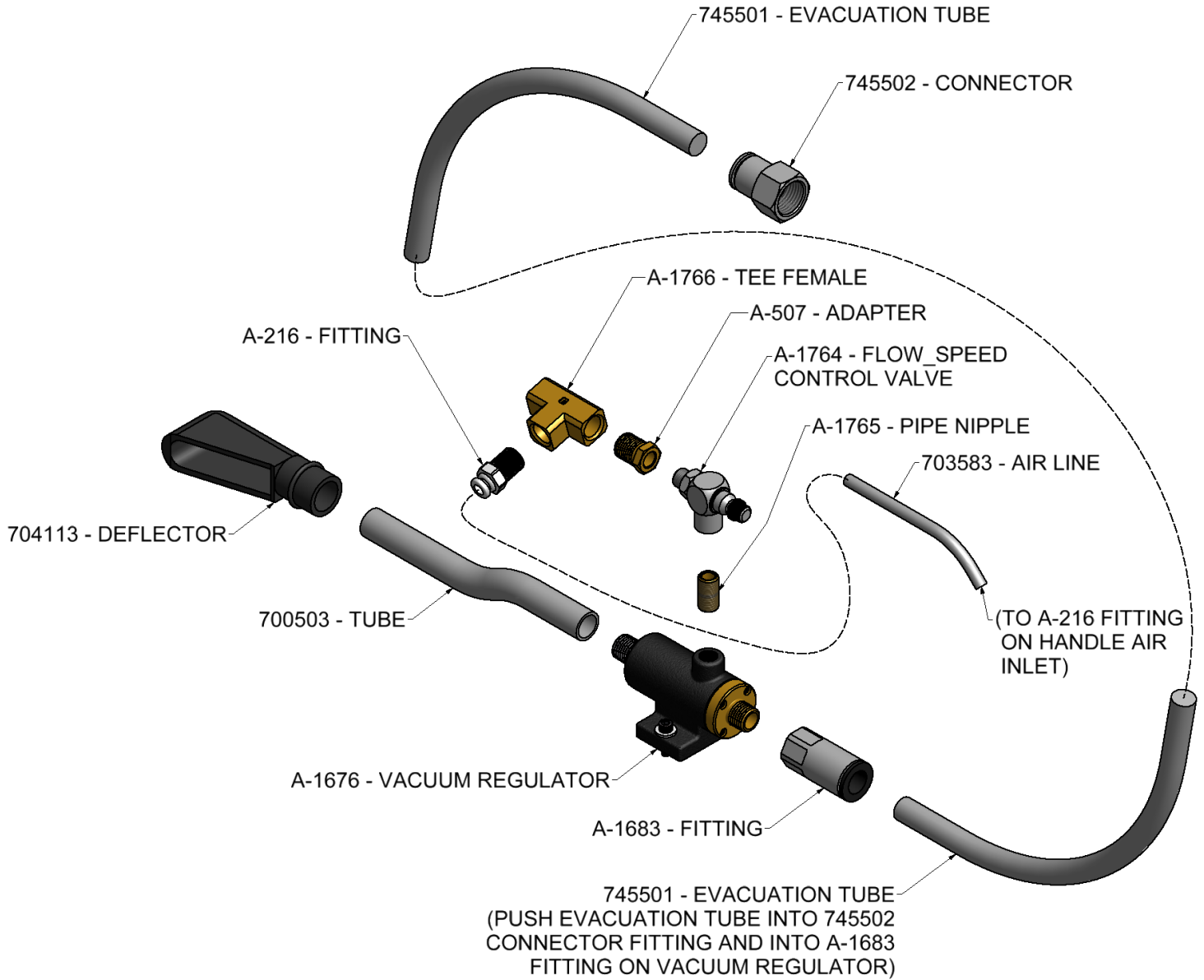

DEXRON® III OIL SAFETY DATA



FIRST AID MEASURES

Eye: No specific first aid measures are required. As a precaution, remove contact lenses, if worn, and flush eyes with water.

Skin: No specific first aid measures are required. As a precaution, remove clothing and shoes if contaminated. To remove the material from skin, use soap and water. Discard contaminated clothing and shoes or thoroughly clean before reuse.

Ingestion: No specific first aid measures are required. Do not induce vomiting. As a precaution, get medical advice.

Inhalation: No specific first aid measures are required. If exposed to excessive levels of material in the air, move the exposed person to fresh air. Get medical attention if coughing or respiratory discomfort occurs.

Note to Physicians: In an accident involving high-pressure equipment, this product may be injected under the skin. Such an accident may result in a small, sometimes bloodless, puncture wound. However, because of its driving force, material injected into a fingertip can be deposited into the palm of the hand. Within 24 hours, there is usually a great deal of swelling, discoloration, and intense throbbing pain. Immediate treatment at a surgical emergency center is recommended.

FIRE

Leaks/ruptures in high pressure system using materials of this type can create a fire hazard when in the vicinity of ignition sources (e.g. open flame, pilot lights, sparks, or electric arcs).

FLAMMABLE PROPERTIES:

Flashpoint: (Cleveland Open Cup) 178 °C (352 °F) Minimum

EXTINGUISHING MEDIA: Use water fog, foam, dry chemical or carbon dioxide (CO₂) to extinguish flames.

PROTECTION OF FIRE FIGHTERS:

Fire Fighting Instructions: This material will burn although it is not easily ignited. See Section 7 for proper handling and storage. For fires involving this material, do not enter any enclosed or confined fire space without proper protective equipment, including self-contained breathing apparatus.

Combustion Products: Highly dependent on combustion conditions. A complex mixture of airborne solids, liquids, and gases including carbon monoxide, carbon dioxide, and unidentified organic compounds will be evolved when this material undergoes combustion.

ACCIDENTAL RELEASE MEASURES

Protective Measures: Eliminate all sources of ignition in vicinity of spilled material.

Spill Management: Stop the source of the release if you can do it without risk. Contain release to prevent further contamination of soil, surface water or groundwater. Clean up spill as soon as possible. Use appropriate techniques such as applying non-combustible absorbent materials or pumping. Where feasible and appropriate, remove contaminated soil. Place contaminated materials in disposable containers and dispose of in a manner consistent with applicable regulations.

ECOLOGICAL INFORMATION

Waste disposal: In accordance with all environmental regulations applicable to your area.

Spillage: Prevent entry into drains, sewers and water course. Soak up with diatomaceous earth or other inert material. Store in appropriate container for disposal.

Ecotoxicity: This material is expected to be harmful to aquatic organisms and may cause long-term adverse effects in the aquatic environment. The ecotoxicity hazard is based on an evaluation of data for the components or a similar material.

HANDLING

Precautionary Measures: DO NOT USE IN HIGH PRESSURE SYSTEMS in the vicinity of flames, sparks and hot surfaces. Use only in well ventilated areas. Keep container closed. Keep out of the reach of children.

General Handling Information: Avoid contaminating soil or releasing this material into sewage and drainage systems and bodies of water.

Static Hazard: Electrostatic charge may accumulate and create a hazardous condition when handling this material. To minimize this hazard, bonding and grounding may be necessary but may not, by themselves, be sufficient. Review all operations which have the potential of generating and accumulating an electrostatic charge and/or a flammable atmosphere (including tank and container filling, splash filling, tank cleaning, sampling, gauging, switch loading, filtering, mixing, agitation, and vacuum truck operations) and use appropriate mitigating procedures.

DISPOSAL CONSIDERATIONS

Use material for its intended purpose or recycle if possible. Oil collection services are available for used oil recycling or disposal. Place contaminated materials in containers and dispose of in a manner consistent with applicable regulations.

GB745SHV5-LB10 ACCESSORIES



Approved for use on Gage Bilt CE installation tools and/or other manufacturer's CE approved tools of similar design.
(Sold Separately)

Grip Gage #269G3

For CHERRYMAX® and CHERRYLOCK® fasteners
(Sold Separately)

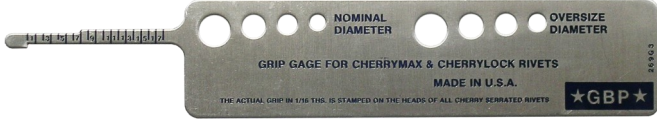

Grip Gage #GB105093

For NAS LOCKBOLTS and blind fasteners
(Sold Separately)



Tool Stroke Depth Gage #A-1935

(Sold Separately)

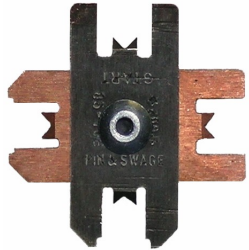

Gage Bilt also supplies pin & collar swage inspection gages to certify swage installation.
(Sold Separately)



Image may not reflect actual gage.

Fill Bottle #745263

(Sold Separately)



Catcher Bag-Stem #756610

(Sold Separately)



Air Bleeder Assembly #704153

(Sold Separately)



Accessories Cont.



*Approved for use on Gage Bilt CE installation tools and/or other manufacturer's CE approved tools of similar design.
(Sold Separately)*

Other adapters available. Contact Gage Bilt for more information.

Adapter Assembly

#745751

Adapts all offset 713 and 752 series noses
(Sold Separately)

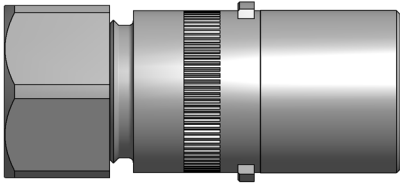

Adapter Assembly

#353204

Adapts all offset 204 series noses
(Sold Separately)

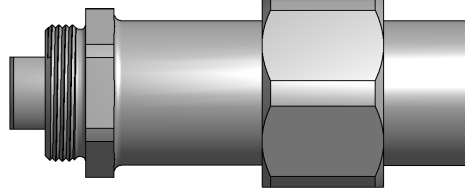

Adapter Assembly

#353205

Adapts all offset 205 series noses
(Sold Separately)

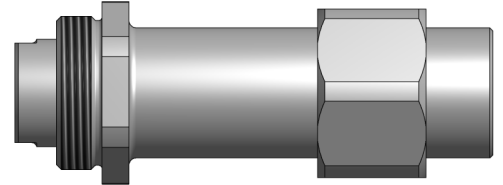

Alternative Styles

(Sold Separately)

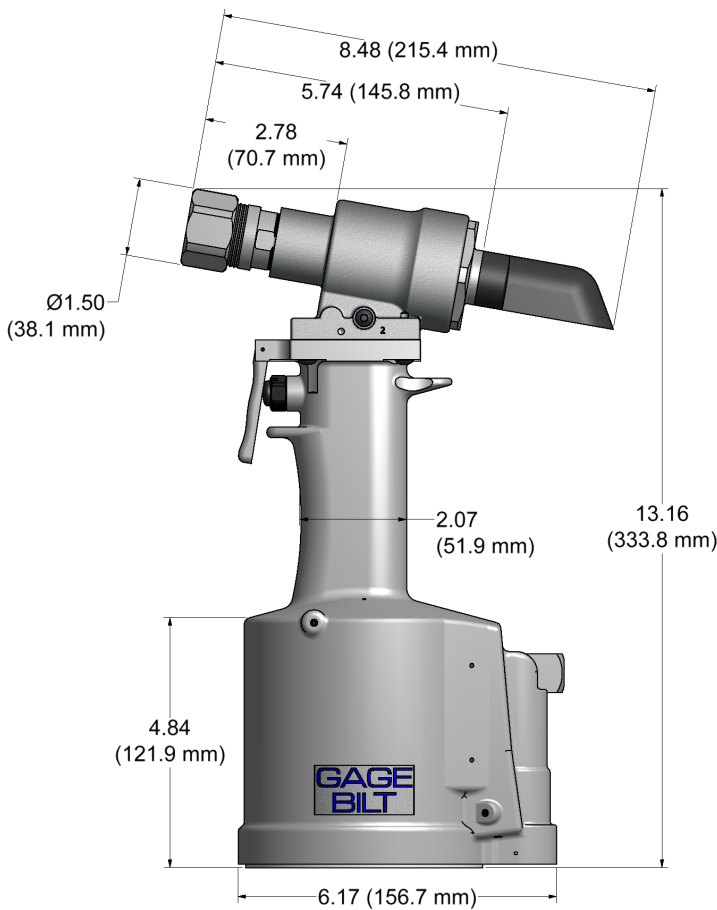

GB745

Stroke - .620" (15.75 mm)
Hand held weight - 7.20 lbs. (3.26 kg)
Pull load - 6,300 (28.02 kN)



GB745SR

Stroke - .620" (15.75 mm)
Hand held weight - 3.00 lbs. (1.36 kg)
Entire tool weight - 10.2 lbs. (4.63 kg)
Pull load - 6,300 (28.02 kN)

*5t Hyd. Hoses are recommended with use of Backpack
Additional custom lengths are available.*



This page intentionally left blank

Riveter Kits Available

(Sold Separately)



Gage Bilt offers a wide selection of standard and custom kits tailored to your needs. Contact us for more information.

CE
Approved



CE
Approved



Split Riveter Tool Backpacks

For 5ft hose Split System Tools.

(Sold Separately)

**SPLIT-SYSTEM TOOL
BACKPACKS**

- Backpack fits any split-system tool
- Reduces weight of tool by up to **70%**
- Reduces User Fatigue
- Increases Productivity
- Increases User Mobility
- Ergonomic
- Comfortable

OPTIONAL

Vacuum System for FOD Control

MAGNA-GRIP® IS A REGISTERED TRADEMARK OF HOWMET AEROSPACE. TEFLON® IS REGISTERED TRADEMARK OF E.I. DUPONT DE NEMOURS & CO. LUBRIPLATE® IS A REGISTERED TRADEMARK OF FISKE BROTHERS REFINING CO. LOCTITE® IS A REGISTERED TRADEMARK OF HENKEL CORPORATION. DEXRON® IS A REGISTERED TRADEMARK OF GENERAL MOTORS CORPORATION. SLIC-TITE® IS A REGISTERED TRADEMARK LA-CO INDUSTRIES. CHERRY® & CHERRYMAX® ARE REGISTERED TRADEMARKS OF CHERRY AEROSPACE.