

GAGE BILT...solutions

Introducing the GB752BBK & GB752BBK-1... Blind Bolt Kit

GAGE BILT now offers a complete tool kit for installing Huck® and Cherry® blind bolts per MS21140 & MS21141 (U or S) and MS90353 & MS90354 (U or S). The basic kit, GB752BBK, contains straight noses to install -5 and -6 diameters, a bleeder bottle, pintail catcher bag and a grip selector gage. The dash one kit also contains right angle noses, offset noses & a stroke limiter. Must items for re-work operations. All these items are stored in an easy access carrying case with manuals and data sheets.







Please view the back of this flyer for pictures of your MS fasteners and noses to match.

GAGE BILT
MADE IN U.S.A.

GAGE BILT Inc.

44766 Centre Court (586) 226-1500
Clinton Twp. MI 48038 (586) 226-1505 Fax
e-mail:solutions@gagebilt.com / www.gagebilt.com

BLIND BOLT	DIA.	NOSE ASSEMBLIES		
		STRAIGHT	RIGHT ANGLE	OFFSET
	5/32"	*SB05-752C-20	**SB05-751B-54RA	SB05-752A-43OS
	5/32"			
	3/16"	*SB06-752C-20	**SB06-751B-54RA	SB06-204D-27OS
	3/16"			

*NOSES LISTED PROTRUDE 2 INCHES FROM THE TOOL. LONGER NOSES ARE AVAILABLE.

**REQUIRES 752140 STROKE LIMITER
 FOR 4.5 INCHES ORDER SBXX-752C-45
 FOR 8.0 INCHES ORDER SBXX-752C-80

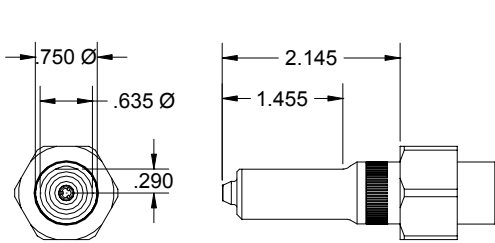

STRAIGHT

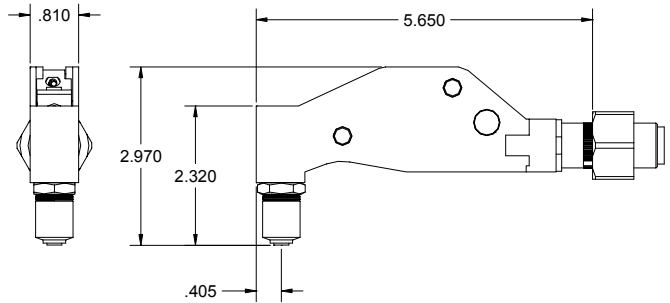

RIGHT ANGLE

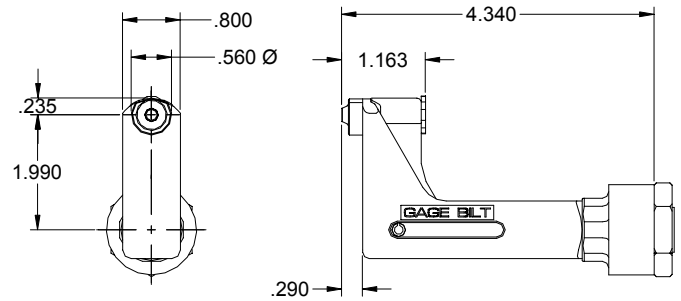
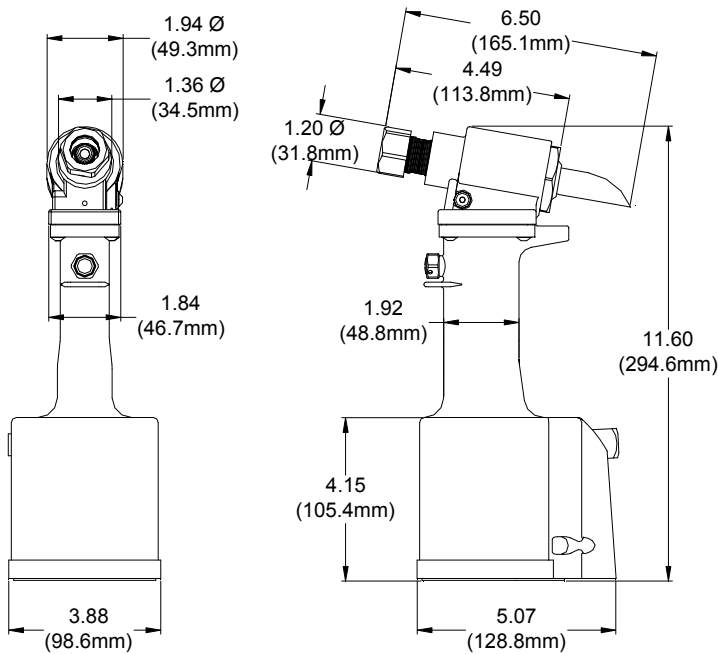

OFFSET