

# 840206 ADAPTER DATA SHEET

To attach adapter and nose to tool:

1. Thread collet adapter (2) onto head piston.
2. With collet placed in nose assembly anvil, tighten both onto anvil adapter assembly (1).
3. Slide anvil adapter (1) over collet adapter (2) and lock into place on tool. Slide drawbar into nose assembly thru adapter assembly.

**CAUTION**

Pintail may eject forcibly.  
Used for closed access applications only to prevent severe personal injury!

To remove adapter and nose from tool  
reverse assembly instructions

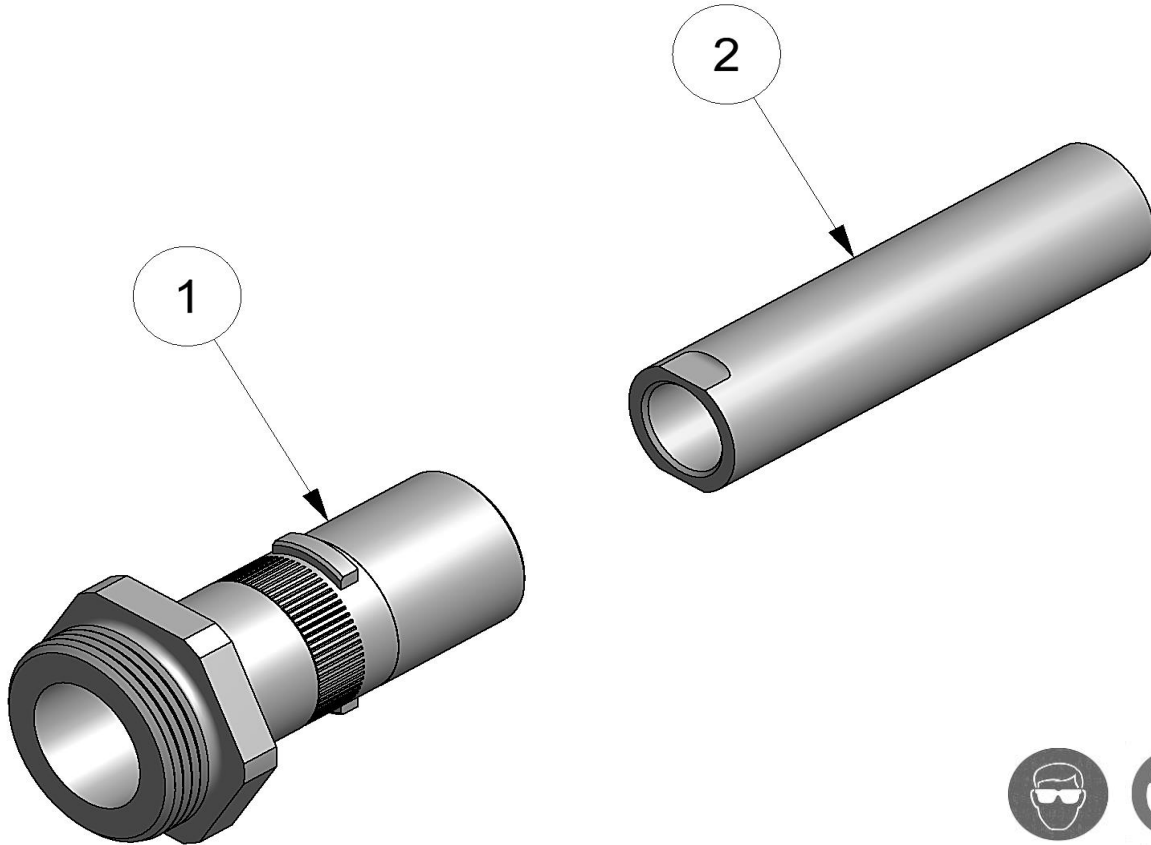

5/15

## GAGE BILT

**GAGE BILT Inc.**

44766 Centre Court (586) 226-1500  
Clinton Twp. MI 48038 (586) 226-1505 Fax  
e-mail:solutions@gagebilt.com / www.gagebilt.com

Type:		Adapts GB206 Series Nose Assemblies to: G83 and G84 tools	
Rotatable Offset Nose Assembly Adapter			
Ref. No.	Qty.	Description	840206
1	1	Anvil Adapter Assy	352207
2	1	Collet Adapter	352208