

# 353209-1 ADAPTER DATA SHEET

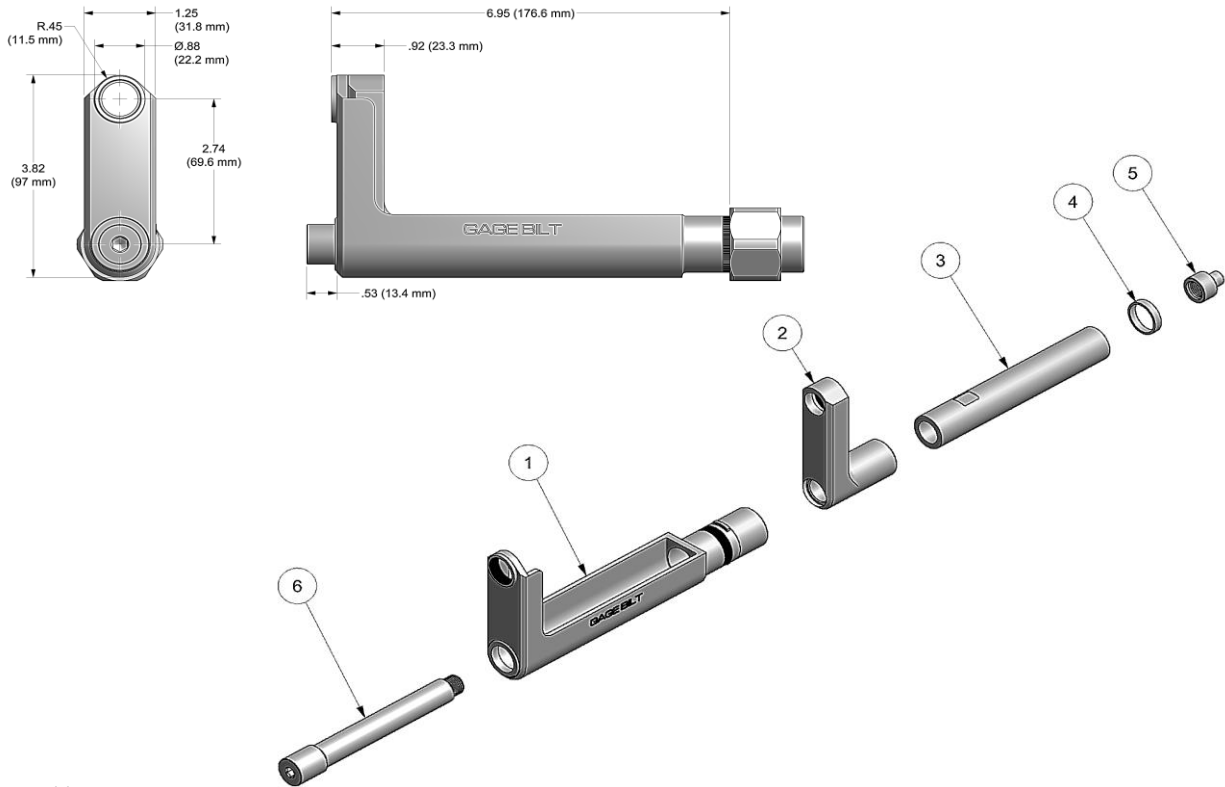

**Assembly Instructions:**

1. Slide spacer (4) over threads on head piston of tool.
2. Insert nut (5) into rear of spacer (3) in direction shown above.
3. Tighten spacer (3) and nut (5) onto head piston of tool using flats provided on spacer and hex in rear of head piston.
4. Insert collet (2) into anvil assy (1).
5. Slide anvil assy (1) and collet (2) into nose fitting of tool and tighten nut onto nose fitting of tool.
6. Slide drawbar (6) thru front of anvil assy (1), collet (2) and spacer (3).
7. Tighten nut (5) onto threaded end of drawbar (6) using tee-wrench (7) thru rear of head piston and hex in front of drawbar.



9/15

## GAGE BILT

**GAGE BILT Inc.**

44766 Centre Court (586) 226-1500  
 Clinton Twp., MI 48038 (586) 226-1505 Fax  
 e-mail:solutions@gagebilt.com / www.gagebilt.com

Type:		Adapts 209 series nose assemblies to: GB745, GB756 and GB2581(A) installation tools	
Rotatable Nose Assembly Adapter			
Ref. No.	Qty.	Description	353209-1
1	1	Anvil Assy	353226
2	1	Collet	353225
3	1	Spacer	353227
4	1	Spacer	353230
5	1	Nut	353218
6	1	Drawbar	71109-1
7	1	Tee-Wrench (not shown)	A-327